



Technical Manual
TRANSDUCER AMPLIFIER
TYPE S7AC

Doc. Ref CD1201W

This manual applies to units of mod status 4 to mod 9F inclusive



BS EN ISO 9001
Certificate No. FM13141



Affirmed by Declaration
of Conformity

USA & Canada
RDP Electrosense Inc.

2216 Pottstown Pike
Pottstown, PA 19465
U.S.A.

Tel (610) 469-0850
Fax (610) 469-0852
E-mail info@rdpe.com
www.rdpe.com

All other countries
RDP Electronics Ltd

Grove Street, Heath Town,
Wolverhampton, WV10 0PY
United Kingdom

Tel: +44 (0) 1902 457512
Fax: +44 (0) 1902 452000
E-mail: sales@rdpe.com
www.rdpe.com

INDEX

1.	INTRODUCTION.....	3
1.1	Certificate of EMC conformity.....	4
2.	INSTALLATION INSTRUCTIONS.....	5
2.1	EMC Requirements	5
2.2	Connections General.....	6
2.3	Typical supply/output connections.....	7
2.4	Transducer connections (LVDT and half bridge)	8
3.	CONTROLS.....	10
3.1	Voltage/Current Output.....	10
3.2	Coarse Gain Selection.....	10
3.3	Fine Gain.....	10
3.4	Coarse Zero.....	10
3.5	Zero Input.....	11
3.6	Fine Zero	11
3.7	Over-Range Indicator	11
3.8	Excitation Frequency	11
3.9	Master/Slave.....	11
4.0	SETTING UP PROCEDURES	12
4.1	LVDT & Half Bridge (Differential Inductance) Transducers	12
5.	SPECIFICATION.....	14
NOTES 15		
6	WARRANTY AND SERVICE	16

TABLE OF FIGURES

Fig. 1	Control locations etc.	6
Fig. 2a	LVDT transducer connections.....	8
Fig. 2b	Half bridge (differential inductance) transducer connections.	8
Fig. 3	Signal Cable Installation for Optimum EMC	9
Fig. 4	Maximum Output Voltage vs. Max. Load Resistance	13
Fig. 5	Maximum load resistance for 20mA output vs. Supply Voltage	13

1. INTRODUCTION

The S7AC is a signal-conditioning unit for use with transducers requiring AC excitation and synchronous demodulation, producing a DC output voltage or current. Units may be master-slaved in systems where carrier frequency beating is a problem.

The unit is housed in a robust aluminium case with connections via glands, all sealed to IP65 specification. All controls are internal with coarse range switches and fine adjustment potentiometers for gain and zero setting. Other controls include a zero-input switch, over-range indicator and pin-mounted components for frequency changing and half-bridge operation.

The unit is suitable for use with the complete range of RDP LVDT transducers.

DECLARATION OF CONFORMITY

**RDP ELECTRONICS LTD.
Grove Street, Heath Town
Wolverhampton, West Midlands
WV10 0PY
United Kingdom**

We declare that the product described in this technical manual is manufactured by RDP Electronics Limited and performs in conformity to the following:

The Electromagnetic Compatibility Directive 89/336/EEC

The Low Voltage Safety Directive 72/23/EEC

**P. J. Smith, C.Eng., MIEE
Director
RDP Electronics Limited**

2. INSTALLATION INSTRUCTIONS

2.1 EMC Requirements

For full EMC compliance, only shielded multi-core cables should be used for connection to this instrument; the cable shield may be terminated by means of a short "pig-tail" and connected to the terminals marked:

- (a) SCN - for transducer cable
- (b) GND - for supply/output cable

With units to Mod.7 onwards status, with metal glands, for optimum EMC the shields should be terminated as shown in Fig.2 (b).

The metal case should be grounded. This would usually be achieved by the use of fixing bolts through the case mounting holes into the (grounded metal) surface the S7AC is mounted on.

NOTES:

1. Cable shields to be grounded at only one end - the S7AC end, although earthing at both ends may reduce the effects of high frequency EMI.
2. When the S7AC is a small part of a large electrical installation, ensure the cables to and from the S7AC are segregated from electrically noisy cables.
3. Ensure cables to and from the S7AC are routed away from any obviously powerful sources of electrical noise, e.g. electric motor, relays, solenoids.
4. ESD precautions should be used when working on the instrument with the lid removed. The user should ensure he is "grounded" by use of an earthed wrist strap or at least touching earth before touching any component including wires, terminals or switches.
5. The transducer body should be grounded. Some transducers such as LVDTs, load cells, etc. without an internal body-to-shield connection, require a separate earth. This should preferably be connected to the instrument shield terminal or as near (electrically) as possible to this point.

2.2 Connections General

Transducer and supply/output connections are made via two screw-clamped terminal blocks mounted on the circuit board adjacent to the two cable glands as shown in Fig.1.

To reverse output polarity, reverse Signal Hi/Signal Lo. With all supplies, voltage output is between OUTPUT and COMMON, which is internally connected to Excitation Lo and Shield. For best results, COMMON should be grounded. NEVER CONNECT COMMON TO V+ OR V-.

Note that when using single supply, the output common is referenced to approximately half the supply voltage and should be monitored with a floating or differential input instrument with sufficient common mode voltage range.

Current (4-20mA) output is between OUTPUT and V-.

WARNING: INCORRECT SUPPLY CONNECTION, e.g. CONNECTING SUPPLY WIRE TO OUTPUT (O/P) MAY DAMAGE THE UNIT AND INVALIDATE THE WARRANTY.

Fig. 1 Control locations etc.

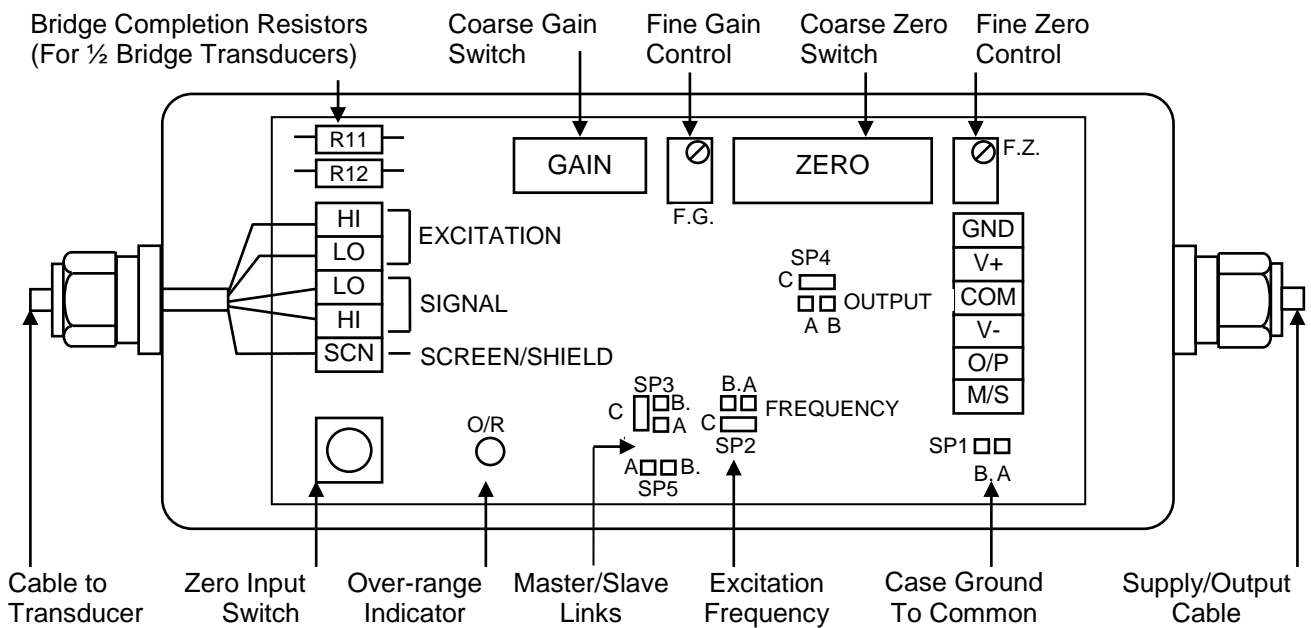

The G'ND terminal is connected to the case.

2.3 Typical supply/output connections

- a) Voltage output, single supply (ensure SP1 is NOT linked, see fig. 1)

This arrangement should only be used if (c) is not possible.

If this arrangement is used, either the supply V- or the output common (or both) must be fully floating. Failure to do this may result in damage to the amplifier that is not covered by warranty.

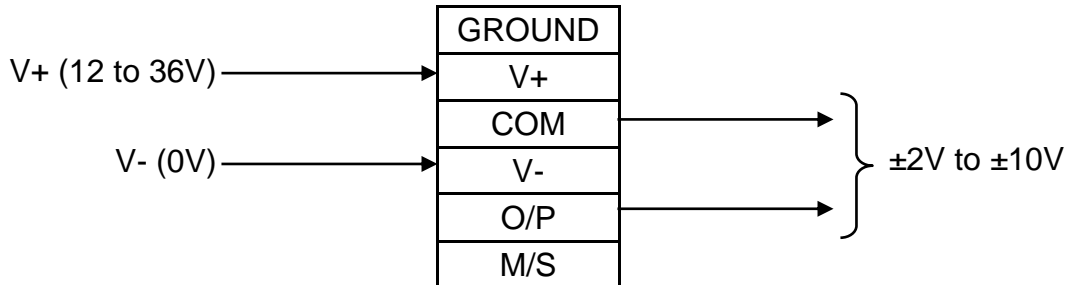

- b) Current output, single supply (ensure SP1 is NOT linked, see fig. 1)

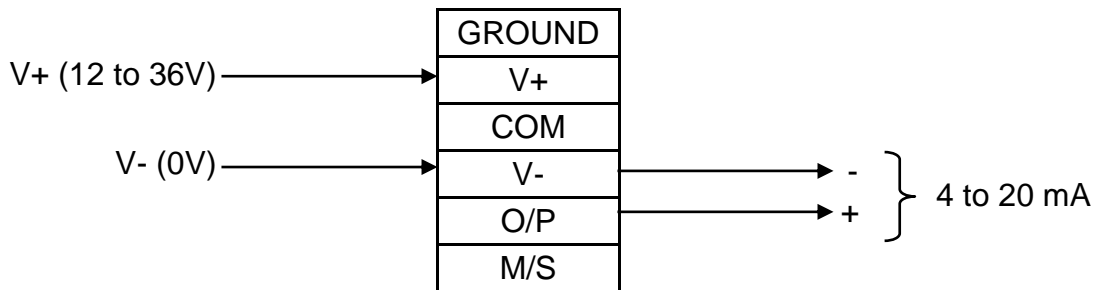

- c) Voltage output, dual supply

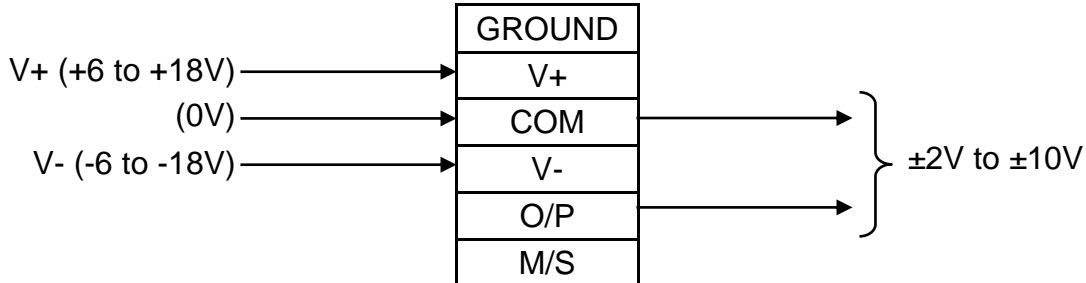

- d) Current output, dual supply

This arrangement should only be used if (b) is not possible.

If this arrangement is used output common (V-) must be floating with respect to supply 0V. Failure to do this may result in damage to the amplifier that is not covered by warranty.

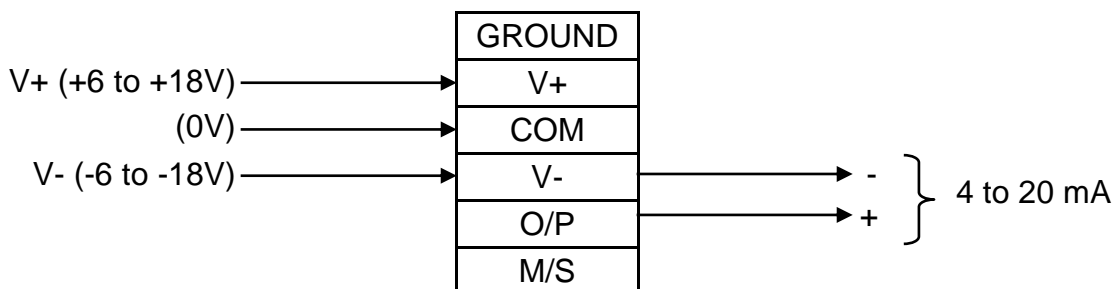

Note 1 In a) and b) the COM (common) terminal floats at 1/2 the supply voltage

Note 2 Ground is connected to the case

2.4 Transducer connections (LVDT and half bridge)

Fig. 2a LVDT transducer connections.

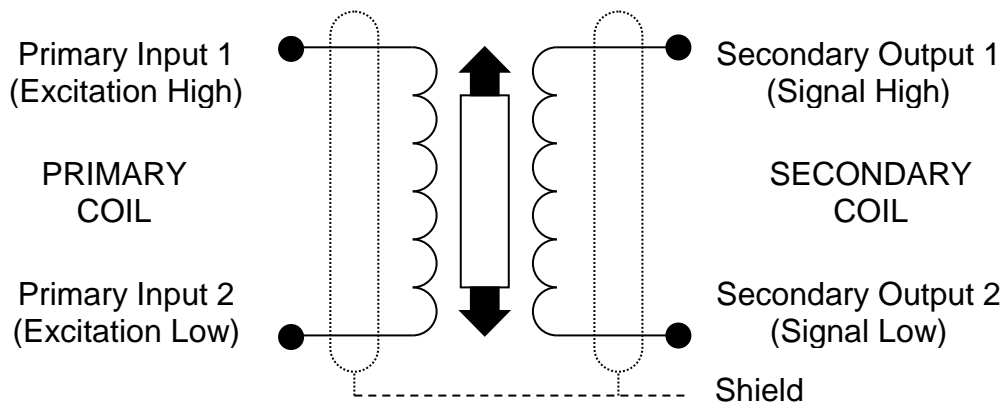

See fig. 1 (or amplifier PCB) for pin designations.

Most RDP LVDT transducers also have a BLACK wire. This is not required with the S7AC amplifier and should be insulated and left unconnected.

If the above configuration does not give the required output phase (i.e. the output *rises* for outward transducer movement instead of *falling*); reverse signal high and signal low connections.

Fig. 2b Half bridge (differential inductance) transducer connections.

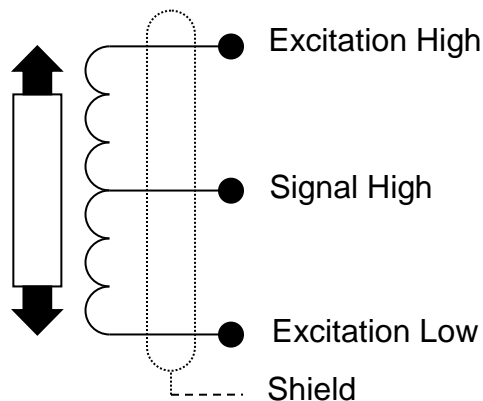

In addition to these connections, it is necessary to add two bridge completion resistors to compensate for the fact that the transducer is only half bridge. For RDP transducers, the resistors should be 1k Ohms, high stability. These should be mounted in R11 and R12 locations, as shown in Fig. 1.

If when connected, the phase of the amplifier output is not as required (for example, an inward moving armature causes a *rising* amplifier output when a *falling* output is required) then reversing the excitation high and excitation low wires will correct this.

Fig. 3 Signal Cable Installation for Optimum EMC

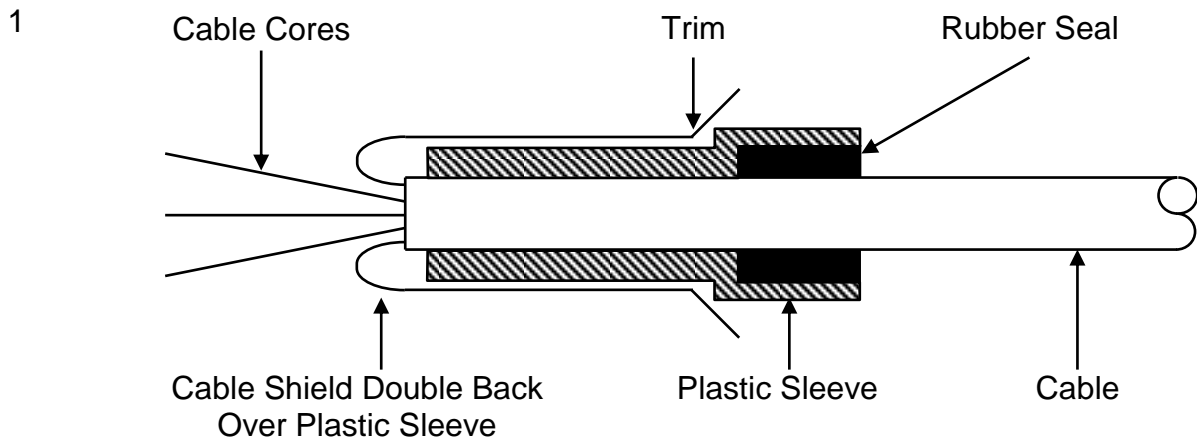

- 2 Insert the end of the cable, plus the plastic sleeve into the metal outer shell of the gland. The bore of the gland is a tight fit onto the cable shield, giving the required ground contact.

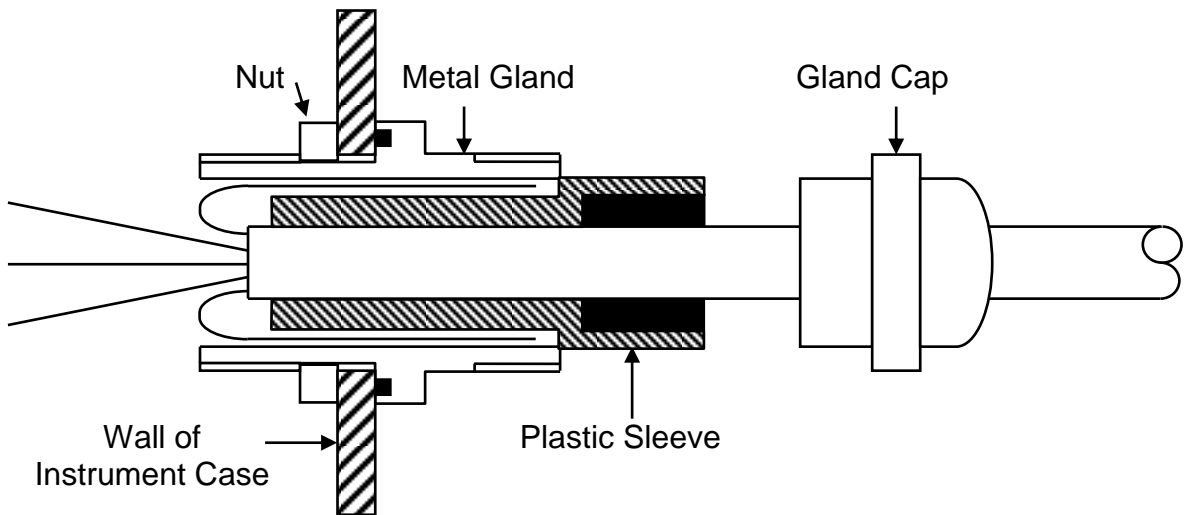

- 3 Fit gland cap and tighten

3. CONTROLS

(For locations, see Figure 1)

3.1 Voltage/Current Output

Solder link SP4 determines which output mode is available at the Output terminal 2 of the supply/output connector. The unit is normally supplied linked for voltage output, i.e. SP4 A-C. For current output change the link to B-C.

3.2 Coarse Gain Selection

Typically, transducer manufacturers' data sheets or calibration certificates will give a figure allowing the full-scale output to be calculated. Possible formats for this are as follows; **the examples assume a transducer range of ±50mm.**

Sensitivity format	Explanation	To convert to F.S. output
mV/V/mm e.g. 46mV/V/mm	Millivolts of output, per volt of excitation, per mm of travel	Sensitivity x 1 x range in mm e.g. 0.046 x 1 x 50 = 2.3V
V/V at full-scale, e.g. 2.3 V/V	Volt of output, per volt of excitation, at full-scale	Sensitivity x 1 e.g. 2.3 x 1 = 2.3V
mV/mm at a specified excitation voltage. E.g. 230mV/mm at 5V exc.	Millivolts of output, per mm of travel, given a specified excitation voltage.	(Sensitivity / specified excitation voltage) x 1 x range in mm e.g. (0.230/5) x 1 x 50=2.3V
The standard excitation of the S7AC is 1V, as used in the calculations above.		

The following table shows the band of transducer full-scale output voltages appropriate to each of the 8 Gain Range Settings. For example, a transducer with a full-scale output of 2.3V would be correctly set as gain range 3.

An 8-position slide switch setting the overall gain in the ranges shown below:

Switch Position	Gain Range (Approximate)	Recommended Input		
		For ±5V O/P	For 4-20mA O/P	For ±10V O/P(Note 2)
1	X0.07 to x0.25	4V max (Note 1)	4V max (Note 1)	4V max (Note 1)
2	0.25 to 0.7	4V max “	4V max “	4V max “
3	0.7 to 2.5	2 – 4V max “	1.7 – 4V max “	4V max “
4	2 to 6	0.8 – 2.5	0.7 – 2	1.6 – 4V max
5	5 to 20	0.3 – 1	0.22 – 0.8	0.6 – 2
6	17 to 50	0.1 – 0.3	0.07 – 0.25	0.2 – 0.6
7	50 to 170	0.03 – 0.1	0.02 – 0.08	0.06 – 0.2
8	170 to 500	0.01 – 0.03	-	0.02 – 0.06

Note 1: For supply ±10V (or 20V) minimum.

Note 2: Refer to Fig.4 re: supply voltage range.

3.3 Fine Gain

A screwdriver-adjusted, 20-turn potentiometer providing a 4:1 adjustment of gain, interpolating between the ranges set by the GAIN RANGE switch.

3.4 Coarse Zero

A 9-position slide switch (position 10 not used) providing output zero shifts of about 1v per step (with Fine Gain at minimum - up to 4v at maximum). When used with ZERO FINE will suppress any output (up to 5v) to zero. Position 5 is normal, i.e. no suppression applied, 6

to 9 suppress negative outputs, 1 to 4 suppress positive outputs. Moving the slider in either direction away from 5 increases the suppression.

3.5 Zero Input

A push-button switch, which, when pressed, zero's the signal, input voltage to the amplifier irrespective of transducer position. This enables a true amplifier zero to be realised.

3.6 Fine Zero

A screwdriver-adjusted, 20-turn potentiometer allowing adjustment of output zero by $\pm 1\text{v}$ to $\pm 4\text{v}$ depending on Fine Gain setting. Used with 3.3 will provide up to 100% suppression.

3.7 Over-Range Indicator

A red lamp that indicates when the demodulator input exceeds the linear range.

3.8 Excitation Frequency

Units are normally supplied with link SP2 fitted A-C for 5kHz excitation. For 2.5kHz, change the link to B-C.

Other frequencies may be selected by changing resistor R33 (on pins) where $R(\text{k}\Omega) = 70 / f(\text{kHz})$, e.g. for 2kHz, $R = 35\text{k}\Omega$

Note: If the frequency is reduced then output noise (ripple) will increase, e.g. for 2.5kHz, 15mV; and 1kHz, 900mV peak to peak.

3.9 Master/Slave

The module may be configured as a master oscillator or slave oscillator via solder links SP3 and SP5.

For Master oscillator link SP3 B-C and SP5 A-B.

For Slave units, link SP3 A-C and remove SP5.

Link the M/S terminal of the supply/output connector of all modules as shown below:

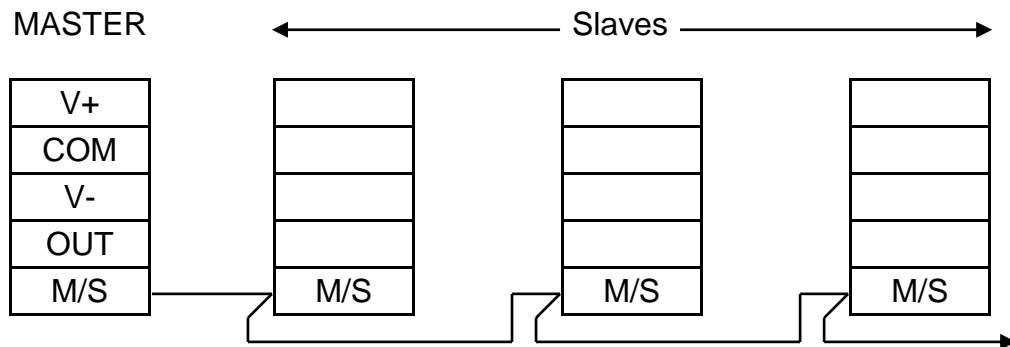

Normally, units are supplied as masters with SP3 linked B-C and SP5 linked A-B, although for a stand-alone unit, SP3 is not essential.

4.0 SETTING UP PROCEDURES

4.1 LVDT & Half Bridge (Differential Inductance) Transducers

4.1.1 Determine the transducer output from the manufacturer's data sheet and set the Coarse Gain control as shown in Sections 3 and 4.

4.1.2 Connect the transducer to the 5-way connector as detailed in Section 2. Switch ON power and allow a 15-minute warm-up period (for maximum accuracy).

4.1.3 Press the ZERO/INPUT switch and adjust the ZERO controls for zero output as shown in Section 3. (For 4-20mA outputs, "zero output" = 12mA). Release the switch.

4.1.4 Adjust the transducer armature for zero output (12mA). The FINE ZERO control may be used to obtain an absolute zero indication if the armature adjustment is too coarse.

Now proceed with either 4.15 or 4.16 according to application.

4.1.5 Bipolar Operation (e.g. $\pm 5V$ or 4-20mA)

(a) Move the transducer armature by a precise amount (e.g. 0.200 inches for a D5/200 transducer) and adjust the FINE GAIN control for the desired output, e.g. 5v, or 20mA.

(b) Relocate the transducer armature at the centre of the stroke and check that the output is zero. Re-adjust the FINE ZERO control if necessary.

Repeat (a) and (b) for consistent results.

(c) Move the armature to the full-scale position in the opposite direction and check for example -5v or 4mA output.

4.1.6 Unipolar Operation (e.g. 0 to 10V)

If it is required that the transducer be used over its entire working range in the one direction, e.g. 0 to 0.4 inches for a D5/200 transducer, then the zero controls are used to "back-off" the signal equivalent to 0.200 inches, then:-

(a) Set up as in 4.1.5, i.e. $\pm 5V$ output for ± 0.2 inches using a D5/200.

(b) Move the armature by exactly 0.200 inches (for a D5/200 transducer) and then adjust the ZERO controls to back off this signal to zero (or 4mA). Now move the armature back 0.400 inches and adjust the FINE GAIN control for the required output.

(c) Repeat (b) until consistent results are obtained. If, for any reason, the coarse gain is changed, restart the whole procedure.

Fig. 4 Maximum Output Voltage vs. Supply Voltage

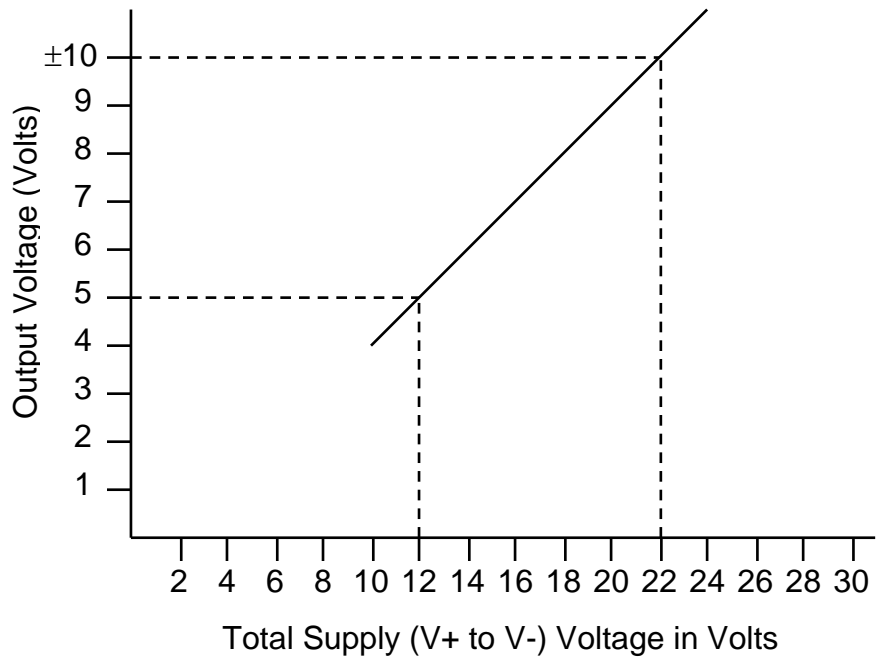
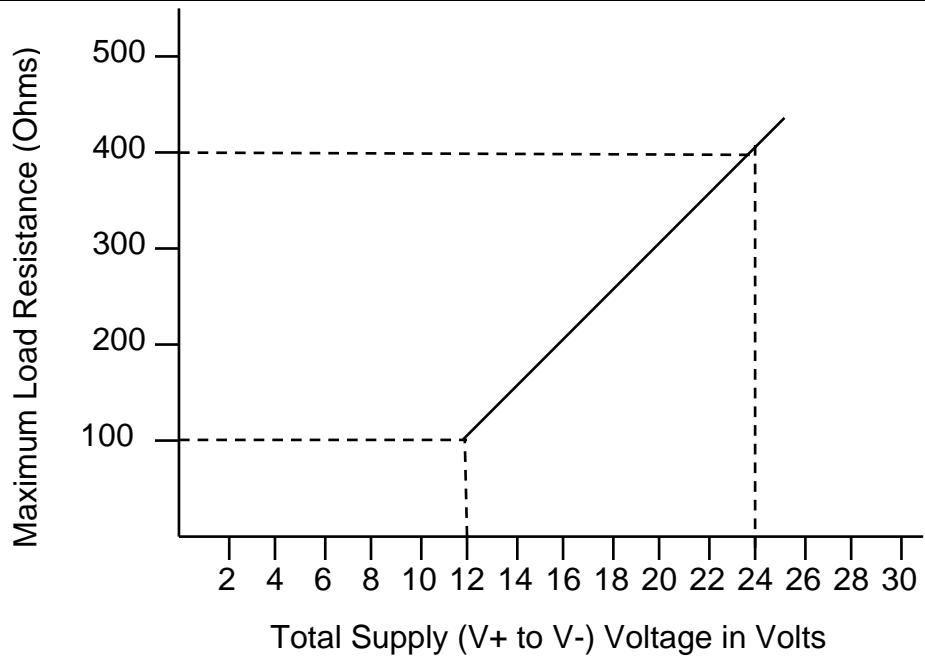

Fig. 5 Maximum load resistance for 20mA output vs. Supply Voltage



5. SPECIFICATION

Supply		±6 to ±18V dc or 12 to +36V dc at 50mA typical
Voltage Output –	dual supply	±4±10V into 2kΩ } Refer to
	single supply	±4V to ±10V into 10kΩ } Fig.4
Regulation		0.5mV/V typical
Current Output-	both supplies	4-20mA into 100/550Ω max.
Regulation		Overload internally limited to 30mA max. 1µA/V typical
Oscillator Output		1V rms. at 5kHz standard. 1kHz – 10kHz via resistor change. 25mA maximum
Oscillator Temperature Coefficient		0.005%/°c typical
Demodulation		Synchronous
Amplifier Gain		x.07 to x500 in 8 ranges with fine control interpolation
Zero Range		±5V minimum
Linearity		0.1% of full scale
Input Resistance		130k ohm differential
Zero Stability	Voltage Output	0.002% of FS typical/°C
	Current Output	0.005% of FS typical/°C
Gain Stability	Voltage Output	0.005% of FS typical/°C
	Current Output	0.01% of FS typical /°C
Bandwidth		Dc to 500Hz (flat)
Noise -Voltage Output		5mV peak to peak typical 10µA peak to peak typical
EMC Specification		When subjected to radiated electro-magnetic energy (as IEC 801-3) an additional error can occur at certain frequencies:
	Field Strength	Typical Maximum Error
	10V/m	1.5%
	3V/m	0.1%
Temperature Range		-10°C to +60°C
Dimensions		6 x 2.5 x 1.5 inches (150 x 64 x 34mm)
Weight		0.8lb (0.35kg)
Gland Cable Diameter		0.12 to 0.26 inches (3 to 6.5mm)
Seals		IP65 specification

6 WARRANTY AND SERVICE

WARRANTY.

R.D.P. Electronics products are warranted against defects in materials or workmanship. This warranty applies for one year from the date of delivery. We will repair or replace products that prove to be defective during the warranty period provided they are returned to R.D.P. Electronics.

This warranty is in lieu of all other warranties, expressed or implied, including the implied warranty of fitness for a particular purpose to the original purchaser or to any other person. R.D.P. Electronics shall not be liable for consequential damages of any kind.

If the instrument is to be returned to R.D.P. Electronics for repair under warranty, it is essential that the type and serial number be quoted, together with full details of any fault.

SERVICE.

We maintain comprehensive after-sales facilities and the instrument can, if necessary be returned to our factory for servicing.

Equipment returned to us for servicing, other than under warranty, must be accompanied by an official order as all repairs and investigations are subject to at least the minimum charge prevailing at the date of return.

The type and serial number of the instrument should always be quoted, together with full details of any fault and services required.

IMPORTANT NOTES.

1.No service work should be undertaken by the customer while the unit is under warranty except with the authorisation of RDP Electronics.

2.If the instrument is to be returned to R.D.P. Electronics for repair, (including repair under warranty) it is essential that it is suitably packed and that carriage is insured and prepaid. R.D.P. Electronics can accept no liability whatsoever for damage sustained during transit.

3.It is regretted that the above warranty only covers repairs carried out at our factory. Should the instrument have been incorporated into other equipment that requires our engineers to perform the repair on site, a charge will be made for the engineer's time to and from the site, plus any expenses incurred.

The aforementioned provisions do not extend the original warranty period of any product that has been either repaired or replaced by R.D.P. Electronics.

**THIS WARRANTY MAY BE NULL AND VOID SHOULD
THE CUSTOMER FAIL TO MEET OUR TERMS OF PAYMENT.**