



# RDP Customer Document

Technical Manual for the  
E725 Microprocessor based  
Transducer Indicator/Controller  
AC INPUT VERSION  
**Doc. Ref CD1420S**

## **Issue S**

This manual applies to units of mod status 6 ONWARDS



BS EN ISO 9001  
Certificate No. FM13141



Affirmed by Declaration  
of Conformity

### **USA & CANADA RDP ELECTROSENSE INC.**

2216 Pottstown Pike  
Pottstown, PA 19465  
U.S.A.

Tel (610) 469-0850  
Fax (610) 469-0852  
E-mail [info@rdpe.com](mailto:info@rdpe.com)  
[www.rdpe.com](http://www.rdpe.com)

### **All other countries RDP ELECTRONICS LTD**

Grove Street, Heath Town,  
Wolverhampton, WV10 0PY  
United Kingdom

Tel: +44 (0)1902 457512  
Fax: +44 (0)1902 452000  
E-mail: [sales@rdpe.com](mailto:sales@rdpe.com)  
[www.rdpe.com](http://www.rdpe.com)

Blank Page

## INDEX

1	INTRODUCTION .....	5
1.1	E725 AC Input Version.....	5
1.2	How to Use This Manual .....	5
1.3	Part Number Structure .....	6
2	EMC DECLARATION & SAFETY TEST INFORMATION.....	7
2.1	Electrical Safety Checks .....	7
2.2	EMC Compliance .....	7
2.3	Certificate of EMC Conformity.....	8
3	INSTALLATION .....	9
3.1	Power Supply Voltage Selection and Connection .....	9
3.2	Display During Power-Up.....	9
3.3	Changing the Fuse.....	10
3.4	Panel Mounting .....	10
4	FRONT PANEL DETAIL & EXTERNAL DIGITAL INPUT CONTROLS .....	11
4.1	Display Features .....	11
4.2	Control Key Functions.....	11
4.3	External Digital Input Controls.....	12
5	TRANSDUCER CONNECTION DETAILS.....	14
5.1	Transducer Connection Overview & Specification .....	14
5.2	Connection for LVDT Transducers (With LVDT Schematic) .....	15
5.3	Connections for Differential Inductance (Half Bridge) Transducers.....	15
6	PROGRAMMING.....	16
6.1	Programming Overview.....	16
6.2	Menu Access.....	16
6.3	Number Entry .....	17
6.4	Menu Item Selection .....	18
6.5	Front Panel.....	19
6.6	Edit Passwords .....	19
6.7	Filter .....	20
6.8	Count Facility .....	20
6.9	Returning To Normal Operating Mode .....	21
6.10	Menu Map .....	21
7	CALIBRATION.....	22
7.1	Calibration Overview .....	22
7.2	Gain Range .....	23
7.3	Decimal Point.....	24
7.4	Calibrate Input.....	24
7.5	Linearise Input.....	28
7.6	Engineering Offset .....	28
7.7	Tare Point.....	28
8	ANALOGUE OUTPUT .....	30
8.1	Analogue Output Description .....	30
8.2	Analogue Output Connections & Specification.....	30
8.3	Analogue Output Calibration .....	30
9	LIMITS.....	32
9.1	Limits Description.....	32
9.2	Connections and Specification .....	32
9.3	Programming Limits .....	34

10	MAX /MIN (PEAK CATCHER).....	36
10.1	How to Identify if Your E725 Has an Option FM Card Fitted .....	36
10.2	MAX/MIN Description (E725 Without Option FM) .....	36
10.3	MAX/MIN Description (E725 With Option FM) .....	36
10.4	MAX/MIN Connections and Specification (E725 Without Option FM) .....	37
10.5	MAX/MIN Connections and Specification (E725 With Option FM) .....	37
11	RS232/RS485 OUTPUTS .....	38
12	TWO CHANNEL VERSIONS .....	39
12.1	Description .....	39
12.2	Connections for Second AC Input Channel.....	39
12.3	Calibrating the Second Transducer.....	40
13	SPECIFICATION.....	41
14	GLOSSARY OF TERMS .....	42
15	APPENDIX 1 – DIMENSIONAL DETAILS .....	44
16	APPENDIX 2 – COMPLETE CONNECTION LISTING .....	45
17	WARRANTY AND SERVICE .....	46

# **1 INTRODUCTION**

YOU DO NOT NEED TO READ THE ENTIRE MANUAL.

Read this section to find out which sections are important.

## **1.1 E725 AC Input Version**

There are several types of unit in the E725 range. This manual is specifically for use with E725 units fitted with ac input board(s). Before proceeding, please check that the part number (located on a label on the E725 housing) has the following structure.

E725-XXX-AC-X-X-X where X is unimportant for the purposes of this exercise.

The AC input E725 is designed to work with a wide range LVDT and half bridge inductive transducers. It provides a display for AC type transducers. It has an analogue output (voltage and current) and four limits as standard. It has excellent dynamic performance and several sophisticated features. One of several option boards can be factory fitted.

## **1.2 How to Use This Manual**

This manual contains all of the information needed to connect and calibrate your transducer. Please spend a little time to read & understand the relevant sections. It is not necessary to read all sections. Please use the index to select the relevant sections.

It is possible that the unit is already calibrated with a transducer. If you have purchased the unit with a calibration then you can probably ignore all sections concerning programming and calibration.

If your unit is not calibrated then read Sections 3, 4, 5, 6 and 7 as a minimum.

### 1.3 Part Number Structure

SUPPLY	230	= 230V ac +5/-15%
	115	= 115 " "
	105	= 105 " "
	5	= 5V dc +50/-10%
	12	= 12 " +50/-25%
	24	= 24 " +50/-25%
INPUT BOARD (One must be chosen)	AC	= for LVDT/half-bridge etc.
	DC1	= for strain gauge & amplified trans. ( $\pm 15V$ supply provided)
	DC2	= for amplified transducers (24V supply voltage provided)
	DC3	= for RDP D2 series transducers
OPTION BOARD (None or one may be chosen)	0	= none
	R	= four mechanical limit relays
	RS	= four solid state limit relays
	FR	= fast limits with two mechanical relays
	FRS	= fast limits with two solid state relays
	FM	= fast MAX/MIN board
	2AC	= Second LVDT/Half-bridge input
	2DC1	= Second DC1 input
	2DC2	= Second DC2 input
2DC3	= Second DC3 input	
SERIAL OUTPUT	0	= RS232
	1	= RS485
SPECIAL OPTION	0	= None
Example:- E725-230-AC-FR-0-0		...has 230V ac supply, and AC input board, a fast limit card, RS232 output and no special options

## 2 EMC DECLARATION & SAFETY TEST INFORMATION

### 2.1 Electrical Safety Checks

This unit is designed to comply with EN 61010-1 "Safety requirements for electrical equipment for measurement, control and laboratory use". The specification complies with the EU Directive 2014/35/EU concerning low voltage electrical safety.

This unit was checked for electrical safety, using a portable appliance test unit, prior to despatch.

If the user wishes to carry out his own PAT tests, the following points must be followed.

- 1) This Safety Class 1 apparatus has a low fuse rating (<3A), and a low current rated power connection cable.
- 2) It is recommended that when carrying out an earth bond test (BS EN 61010-1, Section 6.5.1.2), the test current of 25A should not be applied for more than **six seconds**.
- 3) In general it is **not** recommended that high voltage (e.g. 1.5kV) insulation tests are carried out (BS EN 61010-1, Section 6). This could cause damage to suppresser components.

### 2.2 EMC Compliance

This unit is designed to comply with EN61326-1 "EMC requirements for electrical measurement equipment".

For full EMC compliance, only shielded multi-core cables should be used for connection to this unit; the cable shield to be terminated by means of a short "pig-tail" and connected as detailed in relevant sections of this manual.

The metal rear panel is used as a ground connection for all cable shields. The panel is internally connected to the supply earth wire that must be connected to a reliable ground.

Notes:

- 1) Cable shields to be earthed at only one end - the E725 end.
- 2) Ensure cables to and from the unit are routed away from any obviously powerful sources of electrical noise, e.g. electric motors, relays, solenoids and electrically noisy cables.
- 3) Ideally, the transducer body should not be connected to the cable shield, but should be separately earthed. If the transducer fixing attachments do not provide a good earth, then an earth strap should be used.

## **DECLARATION OF CONFORMITY**

**RDP ELECTRONICS LTD.  
Grove Street Heath Town  
Wolverhampton West Midlands  
WV10 0PY  
United Kingdom**

**We declare that the product described in this technical manual is manufactured by RDP Electronics Limited and performs in conformity to the following:**

**The Electromagnetic Compatibility Directive 2014/30/EU**

**The Low Voltage Safety Directive 2014/35/EU**

**The ROHS2 DIRECTIVE 2011/65/EU**

**R D Garbett  
Director  
RDP Electronics Limited**



### 3 INSTALLATION

#### 3.1 Power Supply Voltage Selection and Connection

Check the supply requirement for the unit using the part number located on the outside of the unit housing:

E725-XXX (ignore the rest)					
If XXX =	<b>5</b>	then supply required is	<b>5V dc, 7W</b>	+50/-10%	<b>dc Supply</b>
If XXX =	<b>12</b>	then supply required is	<b>12V dc, 7W</b>	+50/-25%	
If XXX =	<b>24</b>	then supply required is	<b>24V dc, 7W</b>	+50/-25%	
If XXX =	<b>*105</b>	then supply required is	<b>105V ac, 7VA</b>	+5/-15%	<b>ac Supply (50 - 60 Hz)</b>
If XXX =	<b>*115</b>	then supply required is	<b>115V ac, 7VA</b>	+5/-15%	
If XXX =	<b>*230</b>	then supply required is	<b>230V ac, 7VA</b>	+5/-15%	
*In these cases check that the supply selection slider-switch is correctly set.					

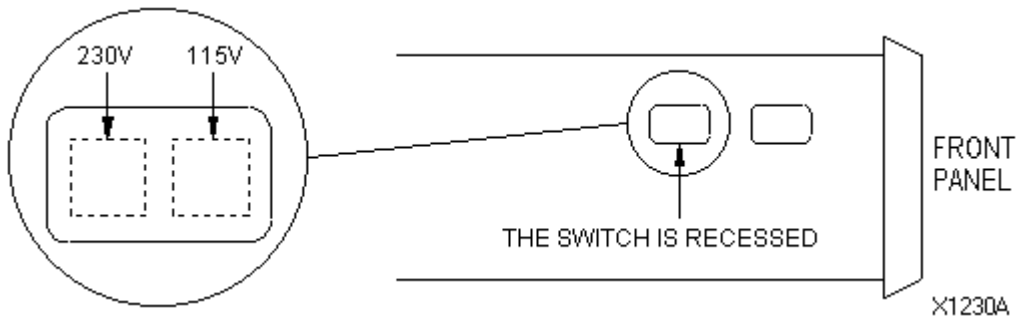

The E725 is fused internally but it is recommended that the unit be externally fused also. We suggest a fuse of a slightly lower rating to the internal fuse (details in Section 3.3). As the unit has no internal power switch it is recommended that an external means of disconnection is fitted in a convenient location, e.g. SW or C.B., etc..

The **ac power supply** is connected to the three-core 2m long integral cable as follows:-

<b>Cable Core</b>	<b>Supply</b>
Brown	Live
Blue	Neutral
Green/yellow	Ground (Earth)

The **optional dc supply**, has integral 2m, two-core shielded cable as follows:-

<b>Cable Core</b>	<b>Supply</b>
Red	dc volts positive
Blue	dc volts negative
Shield (connect to good ground for optimum EMC)	0v/ground

#### 3.2 Display During Power-Up

On power-up the display shows the following before assuming normal operating mode:-

Step	Display	Brief description.	Example
1	E725	The product model number	E725
2	X.XX	A number indicating the software version	1.00
3	AC-X	AC input. X =option card 1 to 4	AC-1
4	XX.Y.Z	The serial communication settings	00.0.4

### 3.3 Changing the Fuse

As the fuse is inside, it is necessary to open the unit in order to change the fuse. Firstly, please obtain the correct fuse as shown below. Section 3.1 details how to identify the power supply required by your unit.

<b>230V ac, 115V ac &amp; 105V ac</b>	units require a	<b>250mA</b>	anti surge (A-S/T type) 20mm long, 5mm diameter.
<b>5V dc</b>	unit requires a	<b>3.15A</b>	anti surge, 20mm long, 5mm dia.
<b>12V dc</b>	unit requires a	<b>1A</b>	anti surge, 20mm long, 5mm dia.
<b>24V dc</b>	unit requires a	<b>0.5A</b>	anti surge, 20mm long, 5mm dia.

**DO NOT USE ANY OTHER VALUE OR TYPE OF FUSE. IT WILL INVALIDATE THE GUARANTEE, IT IS DANGEROUS AND IT MAY CAUSE A FIRE.**

How to install the fuse.

- 1) DISCONNECT THE POWER AND ALL CONNECTORS FROM THE UNIT.
- 2) Place the unit on an anti-static mat and wear earth strap on wrist.
- 3) Remove the four screws, one at each corner of the rear panel.
- 4) Hold the power supply cable grommet and pull the rear panel and circuit boards gently from the unit.
- 5) Remove the two screws that hold the power supply board. The power supply board is on the top of the unit, at the front (near the display).
- 6) Lift the power supply board to reveal the fuse.
- 7) Replace the fuse and re-assemble the unit.

### 3.4 Panel Mounting

This unit may safely be used on a bench or as a portable unit providing that it is not mechanically damaged (by dropping etc) and providing that the supply cable is not damaged.

It may also be installed into a panel if desired.

Panel mounting procedure

The maximum acceptable panel thickness is 12mm. A hole must be cut in the panel 93mm wide and 45mm high. Pass the unit through the panel by firstly feeding the cables through the hole from the outside (front) of the panel and then inserting the unit rear end first.

From the inside of the panel fit the panel-mount clips into the slots on the side of the housing and tighten until the unit is firmly fixed into the panel.

Sealing the front of the unit in a panel.

The membrane keypad of the E725 is sealed into its housing. In order to achieve a seal into the panel, silicone sealant should be applied liberally between the front of the panel and the rear of the unit bezel. This is best done prior to tightening the unit into its panel. The degree of protection is dependent upon how well this job is done but IP65 is possible.





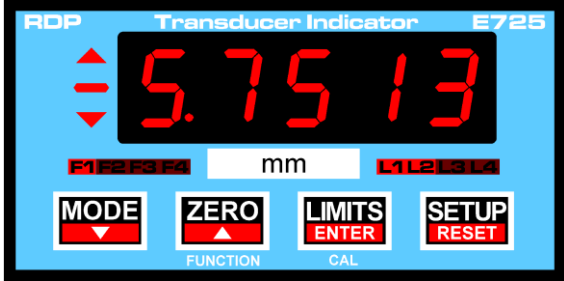







## 4 FRONT PANEL DETAIL & EXTERNAL DIGITAL INPUT CONTROLS

### 4.1 Display Features

<p>The up arrow indicates that the display is showing the MAX value, the down arrow indicates that MIN is being displayed and both together indicate that the TIR is being displayed. (Section 10 refers). The horizontal bar between the up and down arrows provides the negative indication when all 5 digits are in use.</p>		
<p>Four control keys provide functions as described in section 4.2.</p>		<p>The E725 has 5 digits each 13.2mm in height.</p>
<p>Four LEDs (F1 to F4) show the display function MODE. These LEDs are not used on units with a single input unless calculated channels are assigned (Sections 11 and 12 refer).</p>	<p>The white area below the centre of the digits provides space for one of the legend labels (supplied) to be fixed.</p>	<p>Four LEDs indicate the status of the LIMITS. An illuminated LED indicates that a particular LIMIT has been triggered (Section 9 refers).</p>

### 4.2 Control Key Functions

The E725 has four membrane keypads with tactile feedback. These keys select and control the functions of the E725. This section concerns itself only with the functions available in the E725's normal operating mode, it does not detail any of the programming or calibration functions.

Key functions. In order to...	Press...
Zero the display	ZERO 
Return to calibration zero (clear Zero)	ZERO  & RESET  together
Change display (MAX to MIN to TIR to NORMAL)	MODE 
Reset (MAX & MIN & TIR)	MODE  & RESET  together
Change function mode (if available)	MODE  & FUNC.  together
Check the integrity of certain amplifier circuits. A standard E725 AC should show 1.100 APPROX.	MODE  & CAL  together
Reset latched limits	LIMITS  & RESET  together

### 4.3 External Digital Input Controls

Connections are made via the 15-way connector as shown below.

#### 4.3.1 Opto-Isolated Inputs

Digital Input functions. In order to...	Apply 5-50V between pins...
Zero the display	(14 and 10)
Return to calibration zero (clear Zero)	(14 and 10) AND (14 and 12)
Change display (MAX to MIN to TIR to NORMAL)	(14 and 9)
Reset (MAX & MIN & TIR)	(14 and 9) AND (14 and 12)
Change Function mode (if available)	(14 and 9) AND (14 and 10)
Test amp circuits. Should display 1.100 APPROX.	(14 and 9) AND (14 and 11)
Reset latched limits	(14 and 11) AND (14 and 12)
Freeze Display (Digital HOLD)	(14 and 12)
Perform a fast analogue hold.	(14 and 13)

Connections are made via the 15 pin D type connector (labelled 'DIGITAL I/O') on the rear panel. In order to activate the functions a voltage of between 5 and 50V dc is applied between input com. (pin 14) and the required function pin. As the inputs are opto-isolated it is best to use an external supply as this gives the best protection for the unit against electrical interference. If this is not possible, a 5V output available from the same connector may be used, but opto isolation will be lost. If the 5V output from the E725 is used, the common (pin 14) must be grounded by connecting it to pin 8.

15 Pin DIGITAL I/O connector. Pins available for digital inputs.

- |     |  |
|-----|--|
| Pin | Description  |
| 8.  | Ground   |
| 9.  | Same as MODE key for these purposes  |
| 10. | Same as ZERO key for these purposes  |
| 11. | Same as LIMITS key for these purposes  |
| 12. | Same as RESET key for these purposes and also digital HOLD.                            |
| 13. | Fast analogue HOLD.  |
| 14. | Common for all digital inputs  |
| 15. | +5V supply for digital i/p. If used, common (pin 14) must be linked to ground (pin 8). |

Example of resetting MAX/MIN

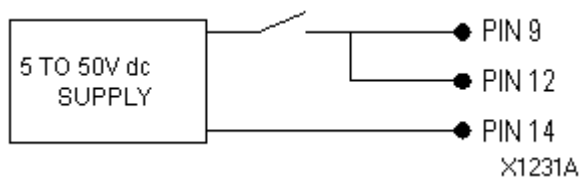

Using an external power supply

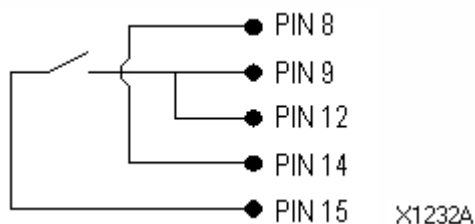

Using the internal 5V supply output

### 4.3.2 Digital Inputs – Specification

<b>Function</b>	<b>Min. pulse</b>	<b>Response</b>	<b>Droop</b>
All digital inputs except hold	200ms	200ms max	N/A
Digital hold, remove signal to release	200ms	200ms max	None
Analogue fast hold, remove signal to release	0.1ms	0.1ms	1 digit/sec typ.

The fast analogue hold freezes both the display and the analogue output. Because it is held as an analogue voltage, it is prone to droop. For best results, Applying the hold to the digital hold 200ms after the analogue hold (a simultaneous hold may be acceptable) will eliminate display droop. However, the analogue output will still droop.

## 5 TRANSDUCER CONNECTION DETAILS

### 5.1 Transducer Connection Overview & Specification

The E725 AC provides the excitation voltage for LVDT and inductive type transducers, as well as having a demodulator to convert the ac signal returned from this type of transducer back into a usable dc signal.

**CONNECTIONS TABLE** for 9 pin D type connector labelled 'TRANSDUCER'

PIN	Pin designation for input card type AC	Comments
1	Excitation high	The polarity of these connections does not normally matter. See "INPUT PHASE" below.
2	Excitation Low, 0V (Ground)	
3	Signal low	The polarity of these connections does not normally matter. See "INPUT PHASE" below.
4	Signal high	
5	0v (Ground)	
6	Master/Slave Link pin (see below)	To synchronise E725s in close proximity.
7	Bridge completion resistor (exc. High)	Only necessary for half bridge type transducers
8	Bridge completion resistor (common)	
9	Bridge completion resistor (exc.low)	
Shell	Cable shield	

#### Input phase.

In most applications it is desirable to have a displacement reading that increases as the transducer moves outward. The above connections reflect this. If however your application requires the reading to increase as the transducer moves inward, reverse the excitation connections (pins 1 and 2), which will reverse the polarity of the display.

#### Master/slave link.

This pin is not normally used. If a number of E725 units, or the transducers connected to them are used in close proximity, there is a possibility of interference. This interference is called 'frequency beating' and is analogous to the audio effect exhibited by twin engined aircraft. In order to eliminate this, the oscillators of the E725 units can be connected together thus synchronising them. If you are using, or intend to use E725 AC units in close proximity and require extreme accuracy, please request document CD1432 from RDP. This gives instructions on the internal changes necessary to synchronise the oscillators of more than one E725 AC.

#### Specification for AC Input Card.

Excitation Voltage	1.1V rms., 30mA sinusoidal
Excitation Frequency	5kHz
Input Impedance	100k Ohms, Differential
Demodulator Type	Synchronous, with active filter
Linearity	±0.05% F.S.
Input Signal Range	F.S. output/display can be achieved for inputs of 0.015 to 4V rms.

Temp. Coefficient	Zero :- $\pm 0.002\%$ F.S./ $^{\circ}\text{C}$ Typical. Gain :- $\pm 0.005\%$ F.S./ $^{\circ}\text{C}$ Typical optimum at $\pm$ full scale. Excitation amplitude :- $\pm 0.005\%$ F.S./ $^{\circ}\text{C}$ Typical
-------------------	---

### 5.2 Connection for LVDT Transducers (With LVDT Schematic)

See also 'INPUT PHASE' above.

The E725 does not require the connection of the secondary centre tap.

For transducers which have a 6 wire connection (i.e. the two secondary coils bought out separately), connect the secondary coils together in series, with one of them reversed, so that they are in differential mode. Connect the series secondaries as if one coil, as shown below.

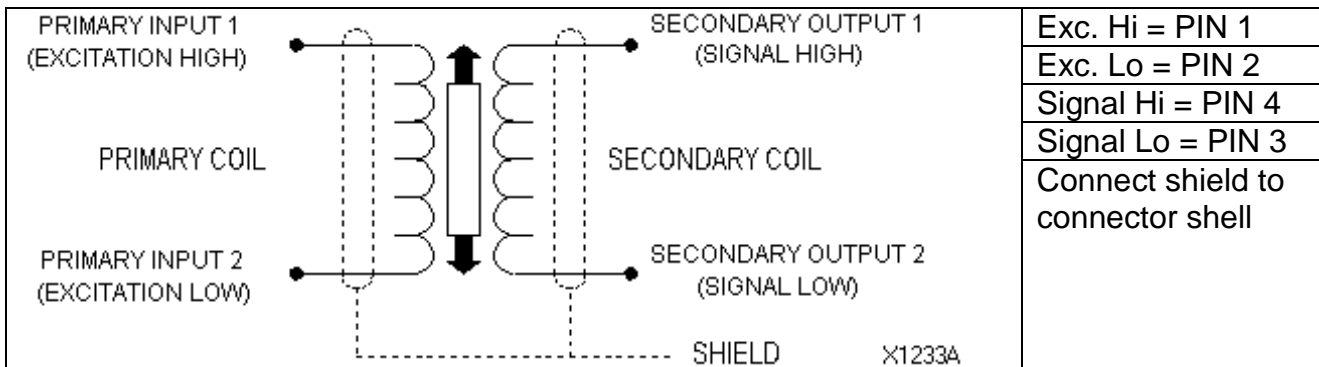

### 5.3 Connections for Differential Inductance (Half Bridge) Transducers

See also 'INPUT PHASE' above.

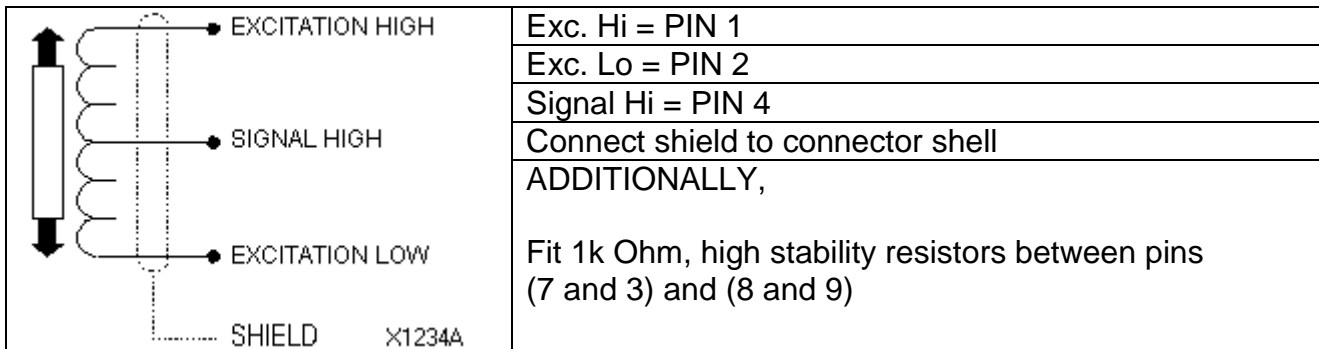

## 6 PROGRAMMING

### 6.1 Programming Overview

Various features of the E725 are user-programmable. This section of the manual outlines the general approach to programming and describes some specific programming steps.

Reading Section 6 should enable the user to access menus, enter numbers, select items and programme some specific features. Programming detail relating to calibration, limits and two channel operation are covered in Sections 7, 9 and 11 respectively.

**SEVERAL EXAMPLES ARE GIVEN, THEY ARE HIGHLIGHTED IN BOXES AND BY THE USE OF THIS FONT. THOSE IN BOLD PRINT ARE LIKELY TO BE PARTICULARLY USEFUL TO THE FIRST TIME USER.**

**It is possible that the E725 has been supplied factory calibrated for use with a specific transducer. In this case, programming may be unnecessary. Care should be taken if programming is attempted as errors may cause the loss of calibration data.**

### 6.2 Menu Access

The E725s programming procedure is based on a menu approach. There are three menus which are called the CONFIGURATION, CALIBRATION and USER SETUP menus.

Access to the menus is protected by three passwords called P1, P2 and P3. Each password is in fact a five digit number (i.e. five digits including leading zeros and sign).

The factory default values and access provided by each password are as follows: -

<u>Password</u>	<u>Default</u>	<u>Access</u>
P1	00001	USER SETUP menu
P2	00002	CALIBRATION and USER SETUP menus
P3	00003	CONFIGURATION, CALIBRATION and USER SETUP menus

It should be noted that the procedure for accessing the CONFIGURATION, CALIBRATION and USER SETUP menus is almost identical. The only difference is the user level which has to be selected and password which has to be entered.

Each menu offers several items, which allow particular features to be programmed. Once a menu has been accessed, the user can step forwards and backwards through that menu, making particular items appear on the display. Once an item is displayed it can be selected to allow a feature to be programmed.

The structure of CONFIGURATION, CALIBRATION and USER SETUP menus is shown in Section 6.10.

The CONFIGURATION menu automatically leads in to the CALIBRATION menu which, in turn, automatically leads in to the USER SETUP menu. In this way the CONFIGURATION menu gives full access to all user-programmable features.



### **EXAMPLE A**

TO ACCESS A MENU FROM THE UNIT'S NORMAL OPERATING MODE, PRESS THE **SETUP** KEY FOR AT LEAST ONE SECOND. THE DISPLAY WILL SHOW THE PROMPT **[UL 1]**. PRESS THE **▲** OR **▼** KEY TO STEP THROUGH THE VARIOUS OPTIONS, WHICH ARE:-

<b>DISPLAY</b>	<b>ACCESS</b>
<b>[UL 1]</b>	USER SETUP MENU
<b>[UL 2]</b>	CALIBRATION AND USER SETUP MENU
<b>[UL 3]</b>	CONFIGURATION, CALIBRATION AND USER SETUP MENU

WHEN THE REQUIRED USER LEVEL IS DISPLAYED, PRESS THE **LIMITS** KEY TO SELECT THE DISPLAYED OPTION. THE DISPLAY WILL NOW SHOW A NUMBER ENTRY PROMPT **[00000]** WITH THE LAST DIGIT FLASHING. AT THIS POINT THE RELEVANT PASSWORD SHOULD BE ENTERED (SEE SECTION 6.3 FOR NUMBER ENTRY.)

### **6.3 Number Entry**

Certain programming steps require number entry. When number entry is required, the display shows a five-digit number with the last digit flashing.

The password number entry prompt is **[00000]**.

In other cases (for example **ENGINEERING OFFSET**) any existing value is shown. For example, if the existing value of **ENGINEERING OFFSET** is 1000, when **ENGINEERING OFFSET** is selected, the display shows **[01000]**, and the last digit is flashing.

Pressing the **UP-ARROW** and **DOWN-ARROW** keys increases and decreases the flashing digit in the range 0 to 9.

Pressing the **ENTER** key accepts the current digit and causes the next (to the left) digit to flash. The user must enter the required number working from right-to-left across the display. The number contains five digits including leading zeros.

Pressing the **RESET** key at any stage in the number entry process discards changes and restarts the process. The original existing value is displayed with the last digit flashing. This is the only way of moving the flashing digit to the right.

A minus sign is entered with the most significant digit (i.e. the one to the left of the display). When the most significant digit is flashing, pressing the **UP-ARROW** and **DOWN-ARROW** keys increases and decreases the flashing digit in the range -9 to +9.

When the display shows the required new value, this number is entered in one of two ways.

- 1) If the most significant digit is flashing, pressing the **ENTER** key enters the new value.
- 2) If any other digit is flashing, pressing the **ENTER** and **RESET** keys together enters the new value. (This alternative simplifies the entry of low values such as 00003, the default value for password P3.)

In both cases the unit accepts the new value and goes to the relevant menu. The display now shows the next item in the relevant menu. In the case of password number entry, if an incorrect password is entered, the unit returns to its normal operating mode.

**EXAMPLE B** (THIS IS INTENDED TO ILLUSTRATE GENERAL POINTS).

TO ENTER THE PASSWORD -00031 FROM THE PASSWORD NUMBER ENTRY PROMPT.

	<b>DISPLAY SHOWS</b>	<b>ACTION</b>
1	0000 <u>0</u>	PRESS UP-ARROW TO CHANGE DIGIT
2	000 <u>0</u> 1	PRESS ENTER TO STEP TO NEXT DIGIT
3	000 <u>0</u> 1	PRESS UP-ARROW THREE TIMES
4	000 <u>3</u> 1	PRESS ENTER TO STEP TO NEXT DIGIT
5	000 <u>3</u> 1	PRESS ENTER TO STEP TO NEXT DIGIT
6	00 <u>0</u> 31	PRESS ENTER TO STEP TO NEXT DIGIT
7	00 <u>0</u> 31	PRESS DOWN-ARROW FOR MINUS SIGN
8	-000 <u>3</u> 1	PRESS ENTER TO ENTER PASSWORD

(AN UNDERLINED DIGIT REPRESENTS A FLASHING DIGIT)

**EXAMPLE C**

TO ENTER THE PASSWORD **00003** (FACTORY DEFAULT VALUE FOR PASSWORD P3) FROM THE NORMAL OPERATING MODE.

	<b>DISPLAY SHOWS</b>	<b>ACTION</b>
1	NUMERIC DATA	PRESS SETUP FOR AT LEAST ONE SECOND
2	0000 <u>0</u>	PRESS UP-ARROW THREE TIMES
3	0000 <u>3</u>	PRESS ENTER & RESET TOGETHER TO ENTER PASSWORD AND GAIN ACCESS TO CONFIGURATION MENU

(AN UNDERLINED DIGIT REPRESENTS A FLASHING DIGIT)

## 6.4 Menu Item Selection

When a menu has been accessed the user can make available items appear on the display using the UP-ARROW and DOWN-ARROW.

**EXAMPLE D** (SEE ALSO MENU MAP, SECTION 6.10).  
**TO STEP THROUGH THE CONFIGURATION MENU, HAVING GAINED ACCESS AS DESCRIBED IN EXAMPLE C.**

	<b>DISPLAY SHOWS</b>	<b>ACTION</b>
1	[FP]	PRESS DOWN-ARROW
2	[Edit.P]	PRESS DOWN-ARROW
3	[GAin]	PRESS UP-ARROW
4	[Edit.P]	PRESS UP-ARROW
5	[FP]	

To select a displayed item, press ENTER. The resulting display depends on which item has been selected. The action required once an item is selected depends on the item in question. Examples of selection of items EDIT PASSWORDS and FILTER are given in the following sections 6.5 and 6.6. Examples of selection of other items are given in Section 7, Calibration and Section 9, Limits.

## 6.5 Front Panel

The item FP allows the user to switch the front panel OFF or ON. Switching the front panel ON allows access to all the normal run-time push button functions (i.e. changing the display mode, zero etc.). Switching the front panel OFF disables all normal run-time push button functions except the SETUP key.

When this item is selected, the user enters a sub-menu comprising two possible options (ON and OFF), The UP-ARROW and DOWN-ARROW keys allow the user to step through this sub-menu. When the required status is displayed, pressing the ENTER key selects the displayed status and exits the sub-menu. Alternatively, pressing the RESET key exits the sub-menu without changing the front panel status. In either case the display will then show [EDIT.P] (Edit Passwords), the next item in the CONFIGURATION menu.

## 6.6 Edit Passwords

**First time users should make themselves generally familiar with the unit before attempting to select the EDIT PASSWORDS item. Incorrect actions could result in the user being locked out of the CONFIGURATION menu.**

EDIT PASSWORDS allows the user to change the passwords from the default values noted in section 6.1. This allows programmed features to be protected by passwords that suit the user.

When this item is selected, the user enters a sub-menu with three items P1, P2 and P3. UP-ARROW and DOWN-ARROW allow the user to step through this sub-menu. When the required item is displayed, pressing ENTER selects that item. The display now shows a number entry prompt with the existing password value. The password can be changed to the required new value as described in general in Section 6.3.

<b>EXAMPLE E (THIS IS NOT RECOMMENDED FOR FIRST TIME USERS)</b>		
TO CHANGE THE CALIBRATION MENU PASSWORD (P2) FROM 00002 TO 00010, HAVING GAINED ACCESS TO THE CONFIGURATION MENU AS PREVIOUSLY DESCRIBED IN EXAMPLE C.		
	<b>DISPLAY SHOWS</b>	<b>ACTION</b>
1	<b>[FP]</b>	PRESS DOWN-ARROW
2	<b>[Edit.P]</b>	PRESS ENTER TO SELECT EDIT PASSWORDS
3	<b>[P1]</b>	PRESS UP-ARROW
4	<b>[P2]</b>	PRESS ENTER TO SELECT PASSWORD 2
5	<b>0000<u>2</u></b>	PRESS DOWN-ARROW TWICE
6	<b>0000<u>0</u></b>	PRESS ENTER TO STEP TO NEXT DIGIT
7	<b>0000<u>0</u></b>	PRESS UP-ARROW
8	<b>000<u>1</u>0</b>	PRESS ENTER & RESET SIMULTANEOUSLY TO ENTER NEW PASSWORD VALUE
9	<b>[P3]</b>	PRESS RESET TO EXIT SUB-MENU
10	<b>[GA<u>i</u>n]</b>	
(AN UNDERLINED DIGIT REPRESENTS A FLASHING DIGIT)		

## 6.7 Filter

The item FILTER allows the user to adjust the –3db point of the digital low pass filter. The digital filtering acts on the display and serial output, but has no effect on the analogue output. The digital low pass filter has nine possible cut off frequencies (-3db point) as shown below.

FILTER VALUE	CUT OFF FREQUENCY (-3db)
1	100 Hz
2	75 Hz
3	50 Hz
4	25 Hz
5	10 Hz
6	7.5Hz
7	5.0Hz
8	2.5Hz
9	1.0Hz

Filter values 6-9 are only applicable to instrument mod. status 8 onwards

When this item is selected the user enters a sub-menu comprising the five possible filter values shown above. The UP-ARROW and DOWN-ARROW keys allow the user to step through this sub-menu. When the required value is displayed, pressing ENTER selects the displayed value and exits the sub-menu. Alternatively, pressing RESET exits the sub-menu without changing the filter value. In either case the display will then show [COUNT] (Count Facility), the next item in the USER SETUP menu.

### **EXAMPLE F**

TO CHANGE **FILTER VALUE** FROM 4 TO 5, HAVING GAINED ACCESS TO THE **CONFIGURATION** MENU AS DESCRIBED IN EXAMPLE C.

#### **DISPLAY SHOWS**

#### **ACTION**

1	[t.Pt]	PRESS DOWN-ARROW
2	[Filt]	PRESS ENTER TO SELECT FILTER
3	[Filt.4]	PRESS UP-ARROW TO CHANGE VALUE
4	[Filt.5]	PRESS ENTER TO SELECT VALUE 5
5	[Count]	

## 6.8 Count Facility

(Only applicable to instruments mod. status 8 onwards)

This facility allows you to enter a number which will force the calibrated input signal to be displayed in the specified resolution. For example, if the display resolution is 2 decimal places and 25 is entered, then the calibrated input signal will be displayed in increments of 0.25 (e.g. 0.00, 0.25, 0.50, etc.). Example G details how to change the count value.

**Notes** – The count facility only applies to the displayed input signal and does not apply to:

1. The cal. signal (i.e. AC excitation voltage, displayed shunt cal. value)
2. Signal used for the software limits or the MAX/MIN/TIR values.
3. Data printed to the RS232/485 port.

### **Example G**

Changing the number of counts having gained access to the CONFIGURATION menu as described in Example C

	<b>Display Shows</b>	<b>Actions</b>
1	[FP]	Press DOWN-ARROW until [Filt] is displayed.
2	[Count]	Press ENTER to edit the number of counts
3	[00000]	Enter the required number of counts (see 6.3)
5	[L1-4]	

## **6.9 Returning To Normal Operating Mode**

When the display is showing any of the OPTIONS in the first level of the CONFIGURATION, CALIBRATION or USER SETUP menus, it is possible to return to the normal operating mode by either of two actions.

- 1) Press RESET.
- 2) Press the DOWN-ARROW key until the display shows **[run]** and then press the ENTER key.

In both cases the display will be blanked and an increasing bar from left to right will be displayed to indicate that the E725 is saving the setup parameters.

## **6.10 Menu Map**

See Section 6.2 for menu access

### **EXAMPLE A (Reminder)**

**TO ACCESS A MENU FROM THE UNIT'S NORMAL OPERATING MODE, PRESS THE SETUP KEY FOR AT LEAST ONE SECOND. THE DISPLAY WILL SHOW THE PROMPT [UL 1]. PRESS THE ▲ OR ▼ KEY TO STEP THROUGH THE VARIOUS OPTIONS WHICH ARE: -**

<b>DISPLAY</b>	<b>ACCESS</b>
[UL 1]	USER SETUP MENU
[UL 2]	CALIBRATION AND USER SETUP MENU
[UL 3]	CONFIGURATION, CALIBRATION AND USER SETUP MENU

WHEN THE REQUIRED USER LEVEL IS DISPLAYED, PRESS THE LIMITS KEY TO SELECT THE DISPLAYED OPTION. THE DISPLAY WILL NOW SHOW A NUMBER ENTRY PROMPT **[00000]** WITH THE LAST DIGIT FLASHING. AT THIS POINT THE RELEVANT PASSWORD SHOULD BE ENTERED (SEE SECTION 6.3 FOR NUMBER ENTRY).

<b>PASSWORD</b>	<b>DISPLAY</b>	<b>MENU ITEM</b>	<b>MANUAL REFERENCE</b>
P3	[FP]	Switch front panel ON/OFF	See Section 6.5
	[Edit.P]	Edit Passwords	See Section 6.6
	[GAin]	Gain Range	See Section 7.2
P2	[dP]	Decimal Point	See Section 7.3
	[CAL.IP]	Calibrate Input	See Section 7.4
	[LIN.IP]	Linearise Input (If applicable)	See Section 7.5
	[E.OFF]	Engineering Offset	See Section 7.6
	[t.Pt]	Tare Point	See Section 7.7
P1	[FILt]	Filter	See Section 6.7
	[Count]	Count Facility	See Section 6.8
	[L 1-4]	Limits setup (standard)	See Section 9
	[L 1-2]	Limits setup (fast limit option)	See Section 9
	[rUN]	Run. Exits menus and returns to normal operating mode	See Section 6.9

## 7 CALIBRATION

### 7.1 Calibration Overview

The E725 can operate with a wide range of transducers. Calibration is a procedure, involving an E725 and a transducer, to set up the E725 to read correctly in engineering units (e.g. mm) as required.

For example, when using an E725 with a displacement transducer, the user may want to see a display of 0 to 100.0 over a displacement range of 0 to 100mm. This is achieved by calibration.

One of several possible approaches to the above example is to position the transducer armature at the inner end of its range and programme the E725 to display 0.0. Having moved the armature a measured 100mm outward, the E725 could be programmed to display 100.0.

This section describes procedures, including programming, for the calibration of a single transducer. If the E725 is fitted with Option 2AC a second channel is available. Details for the calibration of the second channel are given in Section 12.

The E725 has an analogue output, calibration of this is dealt with in Section 8.

The E725 is capable of compensating for transducer non-linearity using either multi-point or polynomial techniques. It is anticipated that many users will not require these facilities, therefore they are covered in separate documentation.

**It is possible that the E725 has been supplied calibrated for use with a specific transducer. In this case calibration should not be necessary and care should be taken not to erase existing calibration data.**

## 7.2 Gain Range

The E725 can accept a full-scale signal in a band from  $\pm 0.015$  to  $\pm 4.0V$  rms. This band is divided into eight ranges numbered 1 to 8.

For many re-calibrations or calibrations of replacement transducers, it may not be necessary to change the gain range. The existing gain range will probably apply in the new situation. For this reason the item GAIN is on the CONFIGURATION rather than the CALIBRATION menu.

However, in general, the gain range will need to be set to suit the transducer being calibrated. This must be done before starting the main calibration procedure (see Section 7.4).

Typically, transducer manufacturers' data sheets or calibration certificates will give a figure allowing the full-scale output to be calculated. Possible formats for this are as follows, **the examples assume a transducer range of  $\pm 50mm$ .**

Sensitivity format	Explanation	To convert to F.S. output
mV/V/mm e.g. 46mV/V/mm	Millivolts of output, per volt of excitation, per mm of travel	Sensitivity x 1.1 x range in mm e.g. $0.046 \times 1.1 \times 50 = 2.53V$
V/V at full-scale, e.g. 2.2 V/V	Volt of output, per volt of excitation, at full-scale	Sensitivity x 1.1 e.g. $2.2 \times 1.1 = 2.42V$
mV/mm at a specified excitation voltage. e.g. 122mV/mm at 5V exc.	Millivolts of output, per mm of travel, given a specified excitation voltage.	(Sensitivity/specified exc. voltage) x 1.1 x range in mm e.g. $(0.122/5) \times 1.1 \times 50 = 1.342V$
The standard excitation of the E725 AC is 1.1V, as used in the calculations above.		

The table shows the band of transducer full-scale output voltages appropriate to each of the 8 Gain Range Settings. For example, a transducer with a full-scale output of 2.53V would be correctly set as gain range 1.	Gain Range	Transducer Full Scale Output (V r.m.s.)
	1	2.0 to 4.0
	2	1.0 to 2.0
	3	0.5 to 1.0
	4	0.25 to 0.5
	5	0.12 to 0.25
	6	0.06 to 0.12
	7	0.03 to 0.06
	8	0.015 to 0.03

To change the gain range it is necessary to understand E725 programming. The user should have read Section 6.

### CHANGING GAIN RANGE WILL ERASE EXISTING CALIBRATION DATA.

When the item GAIN in the CONFIGURATION menu is selected, the user enters a sub-menu comprising the eight possible gain ranges. UP-ARROW and DOWN-ARROW allow the user to step through this sub-menu. When the required range is displayed, pressing ENTER selects that range and exits the sub-menu. Alternatively, pressing RESET exits

the sub-menu without changing the range. In either case the display will then show [DP] (DECIMAL POINT), the first prompt in the CALIBRATION menu.

Exiting the sub-menu via the ENTER key (as opposed to the RESET key) will erase existing calibration data, even if the gain range has not been changed.

<u>EXAMPLE H</u>		
TO CHANGE GAIN RANGE FROM 1 TO 2, HAVING GAINED ACCESS TO THE CONFIGURATION MENU AS DESCRIBED IN EXAMPLE C IN SECTION 6.3		
	DISPLAY SHOWS	ACTION
1	[Edit.P]	PRESS DOWN-ARROW TWICE
2	[Gain]	PRESS ENTER TO SELECT GAIN
3	[Gain.1]	PRESS UP-ARROW TO CHANGE GAIN RANGE
4	[Gain.2]	PRESS ENTER TO SELECT RANGE 2.
5	[dP]	

### 7.3 Decimal Point

Before starting the main calibration procedure (see Section 7.4) it is necessary to set the position of the decimal point. This will define the number of decimal places displayed when in normal operating mode.

To do this it is necessary to understand E725 programming. The user should have read Section 6.

CHANGING DECIMAL POINT WILL ERASE EXISTING CALIBRATION DATA AND LIMIT CONFIGURATION.

When the item DECIMAL POINT in the CALIBRATION menu is selected, the display shows 00000 with the decimal point in its existing position. Its position can be shifted to the left or right by pressing UP-ARROW or DOWN-ARROW respectively. When the decimal point is in the required position, pressing ENTER accepts that position. The user is returned to the CALIBRATION menu, the display shows the next item [CAL.IP] (CALIBRATE INPUT).

### 7.4 Calibrate Input

CALIBRATE INPUT is the menu item where the main calibration procedure must be carried out. Before this procedure is started, the transducer must be connected to the E725 (see Section 5), the gain range must be programmed (see Section 7.2) and the decimal point position must be programmed (see Section 7.3).

For optimum performance the E725 should be allowed to warm up (with excitation applied to the transducer) for at least twenty minutes before calibration.

The user must establish what display arrangement is required. For example, if the transducer in question is a  $\pm 250$  mm LVDT displacement transducer, the E725 may be required to display  $\pm 250.0$  mm, 0 to 500mm,  $\pm 10$  inches etc.

The user must decide on the calibration point. This may be the same as the transducer full-scale, but it may be less. For example, if a user plans to use a  $\pm 25$ mm displacement



transducer over a range of  $\pm 15\text{mm}$ , never moving more than 15mm from centre zero, it would be reasonable to choose a calibration point of 15mm.

Here is a checklist for what the user must decide: -

Engineering units	e.g.	mm
Display full-scale	e.g.	100 mm
Display resolution	e.g.	100.0 mm
Display polarity	e.g.	$\pm 100.0$ mm, reading positive when the armature is in.
Calibration zero point	e.g.	0 displayed at electrical zero.
Calibration point	e.g.	$\pm 80\text{mm}$ (but normally full-scale = 100mm in this case).

To perform a calibration it is necessary to understand E725 programming, The user should have read Section 6.

When the item CALIBRATE INPUT in the CALIBRATION menu is selected, the display shows a number entry prompt. This is the value of the calibration point and can be edited as described in Section 6.3. Pressing ENTER or ENTER and RESET together (as appropriate) selects the value displayed. The E725 enters CALIBRATION MODE, the display shows a transducer reading in counts or engineering units (depends on whether the E725 was already calibrated).

In CALIBRATION MODE, the front panel keys take on specific functions.

MODE and ZERO together	Clears any previous calibration.
ZERO	Fixes the calibration zero point.
ENTER	Takes a cal reading (positive or negative) for bipolar cal.
SETUP	Scales the transducer reading.
MODE and SETUP together	Accepts the calibration and exits CALIBRATION MODE. The display will then show E.OFF, the next relevant item in the CALIBRATION menu.

If it is necessary (e.g. due to an error) to exit CALIBRATION MODE and re-start the main calibration procedure, press MODE and SETUP together. The display shows [E.OFF] (ENGINEERING OFFSET). Press UP-ARROW as required to display item CALIBRATE INPUT, press ENTER to select CALIBRATE INPUT and proceed as before.

<b><u>NOTES REGARDING DISPLAY IN EXAMPLES I AND J.</u></b>	
IN THE FOLLOWING EXAMPLES THE "DISPLAY SHOWS" COLUMN SHOWS THE ACTUAL CHARACTERS THAT WILL APPEAR EXCEPT WHERE MARKED AS FOLLOWS:-	
*1	ANY NUMBER MAY APPEAR (IN COUNTS OR ENGINEERING UNITS).
*2	THE DISPLAY WILL READ TRANSDUCER OUTPUT IN UNCALIBRATED COUNTS. A DISPLAY GREATER THAN 55000 OR LESS THAN -55000 (WHEN THE TRANSDUCER IS WITHIN ITS MEASURING RANGE) INDICATES A PROBLEM. CHECK CONNECTIONS AND GAIN SETTING.
*3	SYSTEM NOISE MAY CAUSE SLIGHT FLUCTUATION ABOUT THE READING SHOWN IN THE EXAMPLE
*4	A DISPLAY OF BETWEEN $\pm 25000$ AND $\pm 55000$ COUNTS CONFIRMS CORRECT GAIN RANGE SETTING.
*5	A DISPLAY OF BETWEEN $\pm 55000$ & $\pm 99999$ COUNTS CONFIRMS CORRECT GAIN RANGE

SETTING.

- \*6 AT THIS STAGE THE ACTUAL DISPLACEMENT (OR OTHER QUANTITY) IS DISPLAYED.
- \*7 RECOMMENDED FULL SCALE IS 50000. OVERRANGE CAPABILITY OF 10% I.E. TO 55000.

### EXAMPLE I- BIPOLAR CALIBRATION

#### POINT TO NOTE REGARDING CALIBRATION OF LVDTs AND HALF-BRIDGE TRANSDUCERS.

LVDTs AND HALF-BRIDGE TRANSDUCERS ARE MOST COMMONLY USED TO MEASURE DISPLACEMENT. THE VAST MAJORITY OF DISPLACEMENT TRANSDUCERS HAVE A MECHANICAL STROKE THAT IS GREATER THAN THE MEASURING RANGE. THESE TRANSDUCERS MUST BE USED WITHIN THEIR MEASURING RANGE OTHERWISE PERFORMANCE (PARTICULARLY LINEARITY) WILL BE COMPROMISED. THE MEASURING RANGE IS USUALLY DEFINED WITH RESPECT TO ELECTRICAL ZERO. THE ELECTRICAL ZERO POINT MUST BE ESTABLISHED AS A PART OF THE CALIBRATION. THIS EXAMPLE INCLUDES THE PROCEDURE FOR ESTABLISHING ELECTRICAL ZERO.

IN MOST CASES IT IS NOT APPROPRIATE TO BASE A CALIBRATION ON THE TRANSDUCER'S FULL MECHANICAL RANGE.

TO CALIBRATE A  $\pm 2$ MM GAUGING TRANSDUCER TO DISPLAY  $\pm 2.000$ MM USING TWO 2MM SLIP BLOCKS.

- 1 ACCESS CONFIGURATION MENU (EXAMPLE C IN SECTION 6.3).
- 2 CHANGE GAIN RANGE IF NECESSARY (SECTION 7.2).

STEPS 1 TO 2 ARE NOT NECESSARY IN SOME SITUATIONS (E.G. RE-CALIBRATIONS). IF STEPS 1 TO 2 ARE TAKEN, THE USER IS AUTOMATICALLY GIVEN ACCESS TO THE CALIBRATION MENU. IF NOT, ACCESS CAN BE VIA PASSWORD P2 (EXAMPLE C IN SECTION 6.3 APPLIES IN GENERAL).

	<b>DISPLAY SHOWS</b>	<b>ACTION</b>
3	[d-P]	PRESS ENTER TO SELECT ITEM DECIMAL POINT.
4	[00000]	PRESS UP-ARROW THREE TIMES TO SHIFT DECIMAL POINT
5	[00.000]	PRESS ENTER TO ACCEPT DECIMAL POINT POSITION
6	[CAL.IP]	PRESS ENTER TO SELECT CALIBRATE INPUT
7	[00.000]	PRESS ENTER 3 TIMES (EDITING CAL PT)
8	[00.000]	PRESS UP-ARROW TWICE (EDITING CAL PT)
9	[02.000]	PRESS ENTER AND RESET TOGETHER (ACCEPTS CAL PT)
10	[43210]	*1 PRESS MODE AND ZERO TOGETHER (CLEARS PREVIOUS CAL)
11	[43210]	*2 ADJUST ARMATURE POSITION TO ACHIEVE DISPLAY AS CLOSE AS POSSIBLE TO ZERO (E.G. WITH A 2MM SLIP BLOCK IN POSITION, ADJUST THEN CLAMP THE POSITION OF THE TRANSDUCER BODY). THIS STEP ESTABLISHES THE ELECTRICAL ZERO (SEE NOTE AT START OF EXAMPLE)
12	[23]	*2 PRESS ZERO
13	[0]	*3 MOVE THE ARMATURE 2MM INWARDS (E.G. INSERT THE SECOND 2MM SLIP BLOCK) PRESS ENTER.
14	[34678]	*4 MOVE THE ARMATURE 4MM OUTWARDS, I.E. 2MM BEYOND ELECTRICAL ZERO (E.G. REMOVE BOTH 2MM SLIP BLOCKS). PRESS ENTER.
15	[34567]	*4 PRESS SETUP (ARMATURE POSITION NOT IMPORTANT HERE)
16	[2.000]	*6 PRESS MODE AND SETUP TOGETHER
17	[E.OFF]	IF NO OTHER MENU ITEMS ARE REQD., EXIT THE CALIBRATION MENU BY PRESSING RESET. AFTER A 2 SECOND DELAY, THE UNIT WILL GO TO NORMAL OPERATING MODE. <b>SEE IMPORTANT NOTE BELOW</b>

\*1, \*2 ETC., SEE NOTE ABOVE HEADED "NOTES REGARDING DISPLAY IN EXAMPLES I & J".

**IMPORTANT NOTE**

**Calibration menus should only be re-accessed by appropriate personnel. Subsequent errors in these menus could lead to a need for re-calibration.**

<u>EXAMPLE J- UNIPOLAR CALIBRATION</u>			
<u>POINT TO NOTE REGARDING CALIBRATION OF LVDTs AND HALF-BRIDGE TRANSDUCERS.</u>			
LVDTs AND HALF-BRIDGE TRANSDUCERS ARE MOST COMMONLY USED TO MEASURE DISPLACEMENT. THE VAST MAJORITY OF DISPLACEMENT TRANSDUCERS HAVE A MECHANICAL STROKE THAT IS GREATER THAN THE MEASURING RANGE. THESE TRANSDUCERS MUST BE USED WITHIN THEIR MEASURING RANGE OTHERWISE PERFORMANCE (PARTICULARLY LINEARITY) WILL BE COMPROMISED. THE MEASURING RANGE IS USUALLY DEFINED WITH RESPECT TO ELECTRICAL ZERO. THE ELECTRICAL ZERO POINT MUST BE ESTABLISHED AS A PART OF THE CALIBRATION. THIS EXAMPLE INCLUDES THE PROCEDURE FOR ESTABLISHING ELECTRICAL ZERO.			
IN MOST CASES IT IS NOT APPROPRIATE TO BASE A CALIBRATION ON THE TRANSDUCER'S FULL MECHANICAL RANGE.			
TO CALIBRATE A ±50MM DISPLACEMENT TRANSDUCER TO DISPLAY 0 TO 100.0MM USING TWO 50MM SLIP BLOCKS. STEPS 1 AND 2 PLUS ASSOCIATED COMMENT ARE AS ABOVE EXAMPLE I.			
	<b>DISPLAY SHOWS</b>		<b>ACTION</b>
3	[DP]		PRESS ENTER TO SELECT ITEM DECIMAL POINT.
4	[00000]		PRESS UP-ARROW TO SHIFT DECIMAL POINT
5	[0000.0]		PRESS ENTER TO ACCEPT DECIMAL POINT POSITION
6	[CAL.IP]		PRESS ENTER TO SELECT CALIBRATE INPUT
7	[0000.0]		PRESS ENTER 3 TIMES (EDITING CAL PT)
8	[0000.0]		PRESS UP-ARROW (EDITING CAL PT)
9	[01000]		PRESS ENTER AND RESET TOGETHER (ACCEPTS CAL PT)
10	[2345]	*1	PRESS MODE AND ZERO TOGETHER (CLEARS PREVIOUS CAL)
11	[2345]	*2	ADJUST ARMATURE POSITION TO ACHIEVE DISPLAY AS CLOSE AS POSSIBLE TO ZERO (E.G. WITH A 50MM SLIP BLOCK IN POSITION, ADJUST THEN CLAMP THE POSITION OF THE TRANSDUCER BODY). THIS STEP ESTABLISHES THE ELECTRICAL ZERO (SEE NOTE AT START OF EXAMPLE). NO KEY PRESSES ARE NECESSARY HERE.
12	[19]	*2	MOVE THE ARMATURE 50MM INWARDS FROM ELECTRICAL ZERO. (E.G. INSERT A SECOND 50MM SLIP BLOCK).
13	[34678]	*2	PRESS ZERO
14	[0]	*3	MOVE THE ARMATURE 100MM OUTWARDS, I.E. 50MM BEYOND ELECTRICAL ZERO (EG REMOVE BOTH 50MM SLIP BLOCKS)
15	[69876]	*5	PRESS SETUP
16	[100.0]	*6	PRESS MODE AND SETUP TOGETHER
17	[E.OFF]		IF NO OTHER MENU ITEMS ARE REQD., EXIT THE CALIBRATION MENU BY PRESSING RESET. AFTER A 2 SEC. DELAY, THE UNIT WILL GO TO NORMAL OPERATING MODE. <b>SEE IMPORTANT NOTE AT END OF EXAMPLE I</b>
*1, *2 ETC., SEE NOTE ABOVE HEADED "NOTES REGARDING DISPLAY IN EXAMPLES I AND J".			

## 7.5 Linearise Input

This item is not present in all versions of the E725. (Lin IP not displayed)

The E725 is capable of compensating for transducer non-linearity using either multi-point or polynomial techniques. The item [LIN.IP] (LINEARISE INPUT) relates to multi-point linearisation. It is anticipated that many users will not require this facility, therefore it is covered in separate documentation (RDP Reference CD1426).

If [LIN.IP] (LINEARISE INPUT) is selected accidentally the display shows the transducer signal in counts or engineering units (depends on calibration status of E725). The user should exit by pressing the MODE and SETUP keys together. The display will then show [E.OFF], the next item in the CALIBRATION menu.

## 7.6 Engineering Offset

The item [E.OFF] (ENGINEERING OFFSET) in the CALIBRATION menu allows an engineering offset to be added to the calibrated transducer signal. For example, if a transducer has been calibrated to read  $\pm 100.0$ mm and the ENGINEERING OFFSET is set to +10.0, in normal operating mode the display will read -90.0 to +110.0 mm.

The ENGINEERING OFFSET is not the same as the CALIBRATION OFFSET, which is fixed during the main calibration procedure (see Section 7.4).

The ENGINEERING OFFSET is not the same as the ZERO DISPLAY function, which is applied via the ZERO key or equivalent digital input (see Sections 4.2 and 4.3).

If an ENGINEERING OFFSET has been programmed, when in normal operating mode the function of the ZERO key (or equivalent digital input) will be to set the display to the value of the ENGINEERING OFFSET (assuming the tare point has not been used to override this, see Section 7.7).

To change the engineering offset it is necessary to understand E725 programming. The user should have read Section 6.

When the item [E.OFF] (ENGINEERING OFFSET) in the CALIBRATION menu is selected, the display shows a number entry prompt. The value is edited as described in general in Section 6.3. Pressing ENTER or ENTER and RESET together (as appropriate) selects the value displayed. The user is returned to the CALIBRATION menu, the display shows the next item, [t.PT] (TARE POINT).

## 7.7 Tare Point

The item [t.PT] (TARE POINT) in the CALIBRATION menu allows a tare point to be defined. The tare point is the reading obtained in normal operating mode when the ZERO key is pressed (or the equivalent digital input is applied).

The default value for the tare point is 0, i.e. when in normal operating mode, pressing the ZERO key sets the display to 0. If an engineering offset is programmed, the tare point is automatically set to the value of the engineering offset.

For example, if a transducer has been calibrated to read  $\pm 100.0\text{mm}$  and the ENGINEERING OFFSET is set to +10.0, in normal operating mode the display will read -90.0 to +110.0mm. The tare point is automatically set to +10.0, so pressing the ZERO key sets the display to +10.0.

It may be necessary to override the arrangement described above. For example, if it is required that a ZERO key operation sets the display to 0 rather than +10.0, this can be achieved by changing the tare point value to 0.

To change the TARE POINT it is necessary to understand E725 programming. The user should have read Section 6.

When the item [T.PT] (TARE POINT) in the CALIBRATION menu is selected, the display shows a number entry prompt. The value is edited as described in general in Section 6.3. Pressing ENTER or ENTER and RESET together (as appropriate) selects the value displayed. The display shows [L 1-4] which is the first item in the LIMITS menu.

## 8 ANALOGUE OUTPUT

### 8.1 Analogue Output Description

The E725 has an analogue output of both voltage (0 to 10V) and current (4-20mA). The output is independent of the microprocessor controller and therefore is unaffected by ZERO commands.

Where the E725 has two input channels, the analogue output represents whichever channel or function has been selected for display (see Section 12).

The analogue output is adjusted using the zero and gain screwdriver potentiometers on the rear panel. These are located at the bottom left of the rear panel and are marked 'Z' and 'G'. The zero and gain potentiometers are common to both the voltage and the 4-20mA output. Therefore, although both may be connected and used, only one can be accurately set up. The zero and gain potentiometers only affect the analogue output, they have no effect on the display.

### 8.2 Analogue Output Connections & Specification

The analogue output mating connector is a 3.5mm diameter, 19mm long stereo jack-plug. The socket is located at the bottom left of the rear panel. The connections are as follows:

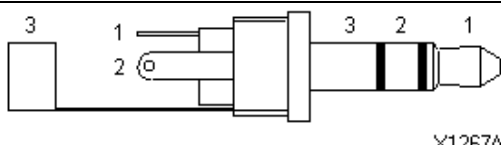
	CONTACT	FUNCTION
	1	4-20mA
	2	0 to 10V
	3	0V (COMMON) & Shield

Specification	
Analogue output (short circuit proof)	0 to 10V (at 5mA max) AND 4-20mA into 0 to 500 Ohms
Analogue output bandwidth	0 to 250Hz
Analogue output ripple (P-P typical)	Voltage: 5mV. 4-20mA: 20µA
Zero pot range	±1.5v or ±2mA
Gain pot range	4:1

General specification may also be relevant. See Section 13. This is an active output that should not be connected to any external power supply, as this will damage unit.

### 8.3 Analogue Output Calibration

The reason for calibrating the analogue output is to ensure that the relationships between the transducer position and the analogue voltage or current output is as required. (e.g. 0 to 10V (or 4-20mA) for -F.S. to +F.S. scale on the transducer). The E725 must be calibrated as described in Section 7 (this may have been done by RDP) before the analogue output is calibrated. The E725 display can then be used in the process of calibrating the analogue output.

In order to calibrate the analogue output the transducer must be positioned accurately at electrical zero and positive full-scale displacement positions. The analogue output must be monitored using a voltmeter or milliammeter depending on the required output (volts or 4-20mA).

The process described in Section 7.2 will have set the gain range for the analogue output. If the gain range value has not been correctly entered, the analogue output may not operate over the full 0 to 10V or 4-20mA range.

The following describes how to calibrate the analogue output of an LVDT transducer. There are both voltage and current (4 to 20mA) outputs from the E725. The voltage output can be calibrated to give 0 to 10V output, and the current output can be calibrated over 4 to 20mA. No other outputs are possible.

Press RESET and ZERO on the front panel to remove any zero offset that may have been applied to the display.

The approach to the calibration will depend upon how the display has been calibrated.

If your unit is calibrated in a bipolar fashion, that is the display goes from a positive value to an equal but negative value, follow approach A to calibration. For example, if you have a  $\pm 50$ mm transducer and the E725 displays  $\pm 50.0$ mm, the display is bipolar calibrated so approach A is appropriate.

If however, your unit has a unipolar calibration, that is the display goes from zero to a positive value, use calibration approach B. For example, if you have a  $\pm 50$ mm transducer calibrated over 0 to 100.0mm, the calibration is unipolar so approach B is appropriate.

#### Calibration Approach A - Bipolar Display

Move the transducer until the display shows zero. Adjust the zero of the analogue output using the rear panel 'Z' control until the output is 5V (for a 0 to 10V calibration) or 12mA (for a 4-20mA calibration)

Move the transducer until the display shows the full-scale positive value. For example, if the transducer has a range of  $\pm 50$ mm, the full-scale positive value is 50.0mm. Adjust the rear panel 'G' (gain) control until the output is 10V (or 20mA).

Check some other display values to make sure that the output is as expected. Once you are satisfied, the calibration of the analogue output is complete.

#### Calibration Approach B - Unipolar Display

Move the transducer until the display shows half of the full-scale display value. Eg, if the display is calibrated over 0 to 100.0mm, the transducer should be positioned such that the display shows 50.0. Adjust the zero of the analogue output using the rear panel 'Z' control until the output is 5V (for a 0 to 10V calibration) or 12mA (for a 4-20mA calibration)

Move the transducer until the display shows the full-scale positive value. For example, if the transducer has a range of  $\pm 50$ mm, the full-scale positive value is 100.0mm. Adjust the rear panel 'G' (gain) control until the output is 10V (or 20mA).

Check some other display values to make sure that the output is as expected. Once you are satisfied, the calibration of the analogue output is complete.

**Note:** Reversing transducer connections will reverse analogue outputs irrespective of display programming.

## 9 LIMITS

### 9.1 Limits Description

The E725 has as standard four Limits. A limit (sometimes referred to as a trip limit or set point) is a facility to indicate when the signal is above or below a certain value. On the standard unit, the indication takes the form of a front panel LED and a TTL output signal available from a rear panel connector.

There are several relay options available and your use of this section will depend on whether you have any of the relay options fitted. Please check the part number of your E725, it is located on a label on the top of the housing.

E725-NNN-NNN-XXX-N-N where XXX is important and NNN is not important here.

If XXX = R,	then the unit has 4 mechanical relays	= Option R
If XXX = RS,	then the unit has 4 solid state relays	= Option RS
If XXX = FR,	then the unit has 2 fast mechanical relays	= Option FR
If XXX = FRS,	then the unit has 2 fast solid state relays	= Option FRS

Any other value of XXX is not relevant to the LIMITS section and indicates that the E725 does not have any LIMIT options fitted, however, TTL outputs are available.

### 9.2 Connections and Specification

Connections for TTL outputs, i.e. no limit option fitted. TTL outputs are available via the connector labelled DIGITAL I/O. Pin numbers are as follows: -

PIN	Description
4	Limit 1 TTL output (Low when front panel LED is OFF)
5	Limit 2 TTL output (Low when front panel LED is OFF)
6	Limit 3 TTL output (Low when front panel LED is OFF)
7	Limit 4 TTL output (Low when front panel LED is OFF)
8	Common for TTL outputs

Connections for the R, RS, FR and FRS options (9 pin D type marked OPTION)

PIN	Mechanical relays (* see following)		Solid state relays	
	Opt R	Opt FR	Opt RS	Opt FRS
1	Relay 1 pole*	Relay 1 (normally open)	Relay 1	Relay 1
2	Relay 1 common	Relay 1 common	Relay 1	Relay 1
3	Relay 2 pole*	Relay 1 (normally closed)	Relay 2	N/A
4	Relay 2 common	Relay 2 (normally open)	Relay 2	Relay 2
5	Relay 3 pole*	Relay 2 common	Relay 3	Relay 2
6	Relay 3 common	Relay 2 (normally closed)	Relay 3	N/A
7	Relay 4 pole*	L1 logic	Relay 4	L1 logic
8	Relay 4 common	L2 logic	Relay 4	L2 logic
9	N/A	Logic common (0V)	N/A	Logic common (0V)
Shell	Cable shield / shield			



- \* For option R only, it is possible to select (see below) whether the relay is normally open or normally closed. The default setting is normally open.  
 In NORMALLY OPEN operation, the relay contacts are OPEN CIRCUIT whilst the front panel LIMIT light is OFF.  
 In NORMALLY CLOSED operation, the relay contacts are CLOSED CIRCUIT whilst the front panel LIMIT light is OFF.

If you need to change the operation of the relays, it is necessary to change some switches on the option card circuit board. This involves opening the case of the E725. Please follow these instructions carefully.

Isolate the power to the E725. Remove all connectors from the rear panel. Undo the 4 screws on the rear panel (black crosshead located in each corner). Observe the necessary precautions for handling static sensitive devices. Holding the power cable grommet, pull until the circuit boards have withdrawn by about 75mm (3"). The switches are now in view (looking from the top of the unit). Their function and position is shown below.

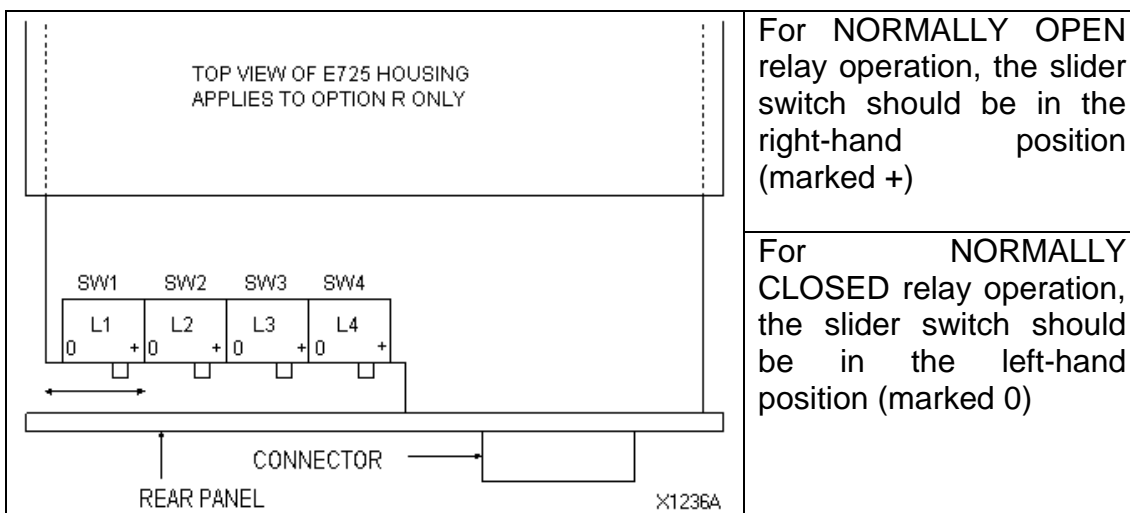

Specification of LIMITS for all versions.

	TTL output	Option R	Option RS	Option FR	Option FRS
Number of relays	None	4	4	2	2
Response time	15ms	20ms	20ms	5ms	5ms
Max voltage (dc)	Zero	150V	200V	150V	200V
Max voltage (ac)	Zero	125V	130V	125V	130V
Max switching	25mA*	30W/60VA	250mA dc 120mA ac	30W/60VA	200mA
On resistance	-	<1 Ohm	10 Ohms	<1 Ohm	10 Ohms
Off resistance	-	Open circuit	10 <sup>12</sup> Ohms	Open circuit	10 <sup>12</sup> Ohms
Accuracy		±1 digit		±0.2% F.S. typical	
Hysteresis		Programmable		±0.2% F.S. typical, fixed**	

\* The total source/sink current for the TTL outputs must not exceed 50mA.

\*\* Ensure optimum gain range is selected in order to minimise the effects of this (analogue) hysteresis on the overall accuracy of Options FR/FRS.

### 9.3 Programming Limits

In order for the limits to function, it is necessary to programme the limit values and some other factors associated with their operation.

Please read Sections 6.1, 6.2, 6.3, & 6.4. This will give essential information on accessing the menu, entering numbers and selecting items from the programming menus. The Menu Map (Section 6.10) may also be useful. Once you have read Sections 6.1 to 6.4, return to this section.

When the Limits menu is accessed, the display reads [L 1-4], denoting Limits 1 to 4. This will read [L 1-2] if you have option FR or FRS fitted as there are 2 limits available with the fast limit option.

Press ENTER.

Press the UP ARROW or DOWN arrow until the display shows the limit you wish to change. For example [L 2]. Press ENTER to select your chosen item.

Again using the UP ARROW and DOWN ARROW keys, choose the operation mode of the limit. The choices and their description are as follows:

- [OFF] OFF. The limit is turned OFF which is the DEFAULT CONDITION. Selecting OFF exits the set up of the current limit. If the current limit is the last limit (L2 for option FR and FRS, L4 for all other cases), the unit will exit the limits menu.
- [HI] HIGH. Limit activates when the input signal is higher than the set point.
- [LO] LOW. Limit activates when the input signal is lower than the set point.
- [d.tion] DEVIATION The limit activates when the input signal deviates from the set point by more than a specified amount. For example, a set point of 100 with a deviation of 10 would be activated below 90 and above 110. DEVIATION is not available with Options FR. FRS.

Press ENTER to make your selection.

The display will briefly show [FUNCT]

Using the UP ARROW and DOWN ARROW keys, view the six LIMIT INPUTS available to be monitored. For most applications the [N-IP] will be appropriate. Full details are as follows:

[n-IP]	NET INPUT	is the value seen on the display of the unit in normal operational mode.	
[G-IP]	GROSS INPUT	disregards any zero offsets introduced (eg by pressing the ZERO key) since calibration	
[t-IP]	TARE INPUT	is the zero offset introduced by the ZERO function	
[n-IP]	WITH MAX INDICATOR	MAX INPUT is monitored	Section 10 gives further details.
[n-IP]	WITH MIN INDICATOR.	MIN INPUT is monitored..	
[n-IP]	WITH TIR INDICATOR.	TIR INPUT is monitored.	

Press ENTER to make your selection.

**Number entry, quick refresher!**

*Increment/decrement a digit using the UP ARROW or DOWN ARROW key.*

*Step digits using the ENTER key*

*Enter the value using the ENTER and SETUP keys together or if the left-hand digit is flashing, by pressing ENTER.*

*In order to correct an error, press RESET to return to the original value.*

*Negative numbers are entered using the left-hand digit.*

The display will briefly show [SET.PT] (SET POINT) and then show a number. Enter the required value of the set point. It can be any value between minus 99999 and plus 99999. Section 6.3 deals with number entry if you're not sure.

If you have selected [d.tion] (DEVIATION) as the operation mode, the unit will at this point request the level of deviation allowed. ([d.tion] will appear on the display briefly). Input this value. THIS STEP WILL BE OMITTED IF THE OPERATION MODE IS NOT [d.tion].

Next the unit will momentarily display [HYS] (HYSTERISIS). Hysteresis provides a dead band around the limit value. If for example, the signal from the sensor has a lot of fluctuation, as the average signal approaches the set point, the limit will be rapidly triggered on and off. The hysteresis value allows a dead band to be configured. If for example the limit is a high limit with a set point of 100 and hysteresis of 10, the limit will trigger at 100 but not go off until 90.

Hysteresis is not programmable with Options FR/ FRS.

Finally, the display will show [LAT-N] (LATCHING NO). This sets the limits to be non-latching. If this is set to [LAT-Y] (LATCHING YES) using the UP ARROW key, once the limit is triggered, it will stay triggered even if the signal falls below the set point. The limit must be reset before it will go off. See Section 4 for details of how latched limits are reset. Press ENTER once the required selection is made. Note: latching LOW limits are inoperable for FR/FRS options.

The display will now prompt entry of the next limit unless this was the last limit (L4 for R and RS, and L2 for FR and FRS). If it was the last limit, the display will show RUN. Press enter (and wait for 2 seconds). The unit has now left set-up mode and is in normal operating mode.

To make a quick exit from the limits menu, whilst the display is showing [L1], [L2, L3] or [L4], press RESET. The display will then show [RUN]. Press ENTER and after a 2 second delay, the unit will return to normal operating mode.

## **10 MAX /MIN (PEAK CATCHER)**

### **10.1 How to Identify if Your E725 Has an Option FM Card Fitted**

Please compare the part number of your E725 (located on a label on top of the housing) with the following:

E725-NNN-NNN-XXX-N-N where XXX is important and NNN is not important here.

If XXX = FM, then the unit has option FM (also referred to as fast MAX/MIN or Peak catcher) fitted.

Any other value of XXX is not relevant to this section and indicates that the E725 does not have option FM. However, the standard MAX/MIN features are still available.

### **10.2 MAX/MIN Description (E725 Without Option FM)**

The standard E725 monitors the transducer signal and stores the maximum (MAX), minimum (MIN), and the total indicated range (TIR). The total indicated range is the difference between the maximum and the minimum.

To the left of the display, the up arrow (triangle) indicates that the display is showing the MAX value, the down arrow indicates that MIN is being displayed and both together indicate that the TIR is being displayed. Pressing the MODE key rotates the display NORMAL to MAX to MIN to TIR to NORMAL etc. An external device may also switch modes using the digital inputs. Section 4.3 gives further information.

Pressing MODE and RESET together resets the MAX/MIN value.

### **10.3 MAX/MIN Description (E725 With Option FM)**

Please use Section 10.1 to check if your unit has Option FM fitted.

To the left of the display, the up arrow (triangle) indicates that the display is showing the MAX value, the down arrow indicates that MIN is being displayed and both together indicate that the TIR is being displayed. Pressing the MODE key rotates the display NORMAL to MAX to MIN to TIR to NORMAL etc. An external device may also switch modes using the digital inputs. Section 4.3 gives further information.

The MAX/MIN value is reset by pressing MODE and RESET together or by using the RESET input on the FM option board connector. (See also section 10.5)

Option FM provides a fast analogue peak catcher which uses analogue comparators to catch the MAX (peak) and MIN (trough or valley) of the input signal. The peak catcher is suited to very rapidly changing signals. Please note that the MAX and MIN signals are stored as analogue values and so may flicker slightly due to electrical interference. Also, there will be a signal droop that is normally negative-going.

In addition to the standard analogue output (see Section 8), there is an analogue output available from the FM option board connector. The FM analogue output is a non-scaled version of the stored value. If the coarse gain range is correctly set for the transducer, the output of the peak for example, should be between 5V and 10V for a peak value equal to the full-scale range of the transducer.

In order accurately to identify the relationship between the FM analogue output and the displayed peak value, measure the FM analogue output voltage and then compare it with the peak value shown on the E725 display.

The TIR (difference between MAX & MIN) has the possibility of being twice the F.S. value of the transducer. For this reason the analogue output of TIR is halved.

#### 10.4 MAX/MIN Connections and Specification (E725 Without Option FM)

The standard E725 connections for externally changing display mode and resetting MAX / MIN and TIR are given in section 4.3.

Specification for MAX/MIN (E725 Without Option FM).

Range of capture.	Any value between -99999 and +99999
Min pulse width for $\pm 1$ digit accuracy	Guideline figures:- 40ms at filter value 1, 100ms at filter value 5

#### 10.5 MAX/MIN Connections and Specification (E725 With Option FM)

The FM board can be fully controlled from the front panel. However, if external control is required or an analogue output of the MAX or MIN value is required, connections can be made to the card.

The connections are made using the 9 pin D plug (supplied) to the connector marked OPTION on the rear of the E725. The connections and their descriptions are as follows:-

PIN	Function	Description
1	MAX output	Voltage between pin 1 and 4 proportional to MAX
2	MIN output	Voltage between pin 2 and 4 proportional to MIN
3	TIR output	Voltage between pin 3 and 4 proportional to TIR/2
4	Analogue common	Common for above analogue outputs
5	Reset	Resets stored MAX and MIN when linked to pin 6
6	+5V	5V output for above.
7	MAX comparator O/P	Logic O/P. Goes low when input sig. > current MAX.
8	MIN comparator O/P	Logic O/P. Goes low when input sig. < current MIN.
9	Digital common	Common for Pins 7 & 8
Shield	Cable shield	Cable shield/ Shield.

Option FM can be reset using the connector labelled DIGITAL I/O (see section 4.3) or by using the pin 5 of connector marked OPTION.

## Specification for OPTION FM

Range of capture	Any value between -99999 and +99999
Accuracy for 0 to FS step.	Change in 10ms = 0.1% FS Change in 1ms = 0.2% FS
Drift (droop)	Typically 1 digit per 3 seconds, normally negative going, even if the signal is negative.

### Notes

- 1) The E725 FM has a very rapid response to transient signals. Ensure that the E725 has adequate supply-noise suppression otherwise erroneous MAX/MIN values may be stored.
- 2) When the MAX/MIN is RESET, there will nearly always be some residual value (i.e. not exactly zero). This is due to the small amount of noise inherent on the signal. The display may appear stable due to the digital filtering.
- 3) Remember that the FM board is designed to store fast peaks. If there is a fast transient information on your signal due to mechanical or electrical noise, the FM board will catch it. The FM board is not able to discriminate between desirable and undesirable MAX or MIN values.
- 4) If you do encounter problems with unexpected peak values, monitor the signal with an oscilloscope in order to see what is causing them. They are almost always due to noise induced into cabling from motors, solenoids or other electrically noisy equipment.
- 5) If you wish to display or store a fast MAX or MIN value for a long time, use the digital HOLD function (see Section 4.3 for details)

## 11 RS232/RS485 OUTPUTS

The E725 is fitted with an RS232 output as standard, or an RS485 output as an option.

The last-but-one digit of the part number indicates whether the RS485 option is fitted. If it is a '0' the output is RS232, if it is a '1' the output is RS485.

The serial outputs enable the user to connect one E725 using RS232, or up to 256 E725 units using RS485, to a computer. This allows the display reading for example to be directly transferred to a PC.

In addition to this, a PC may take operational control of the unit, enabling actioning of all front panel (and other) functions.

Calculated channels may be defined, allowing for example the display to read different engineering units (user selectable) for the same transducer input.

Recognising that only a small number of customers use RS232 and in an attempt to save paper, there are no further details of the RS232 or RS485 output in this manual.

Please contact RDP or your distributor to order a copy of the full Serial Communications Manual, part number CD1423.

## 12 TWO CHANNEL VERSIONS

### 12.1 Description

If the 2AC option has been factory fitted, two identical transducers may be connected to the E725. Compare the part number with the following to establish if it is fitted.

E725-NNN-NNN-XXX-N-N where XXX is important and NNN is not important here.

If XXX = 2AC, then the unit has two AC input boards fitted, any other value of XXX is not relevant to this section.

The second channel is designed to allow a second transducer to be connected. The two transducers must have the same linear range and must have a full-scale sensitivity within  $\pm 15\%$  of each other. They must also display the same full-scale value.

The second input is connected to the OPTION slot. It uses a 9 pin D type.

When an E725 is fitted with a second input card, four display functions are activated. To move between functions, press MODE and FUNCTION together. The 4 LEDs marked F1 to F4 located just above the MODE key indicate the function that is selected, as follows: -

F1	A	Transducer A input.	Limit & MAX/MIN monitor selected function. MAX/MIN and any latched limits are reset when the function mode is changed.
F2	B	Transducer B input	
F3	$(A+B)/2$	Average of A and B input.	
F4	A-B	Difference between A and B	

**ZERO FUNCTION.** Each of the modes has a separate zero point. Therefore, pressing ZERO whilst in mode F1 (transducer A) will have no effect on the calculation of A-B (mode F4) for example. If modes F3 or F4 appear to be incorrect, RESET ZERO on all four modes to ensure that all modes have the zero offset removed. Calculations should now be correct.

**ANALOGUE OUTPUT.** The analogue output is proportional to the currently selected mode.

It is vital that the correct zero is set, i.e. centre-stroke displacement corresponds to 5V (or 12mA) analogue output. This may be checked by unplugging the relevant transducer and checking for 5V. Always ensure that when changing mode etc. the ZERO key is not accidentally pressed producing misleading display/output results.

### 12.2 Connections for Second AC Input Channel

The connections for LVDT transducers are the same EXCEPT that the secondary connections (pins 3 and 4) must be reversed. Refer to Section 5 for connections for the first transducer. For differential inductance (half-bridge) transducers please contact RDP or your distributor for a copy of Application Note CD1454.

## 12.3 Calibrating the Second Transducer

This section assumes that the first transducer is calibrated. If not, see Section 7. Select F2 (Transducer B input). See above for how to do this.

### 12.3.1 Bipolar Calibration

Press the RESET and ZERO keys together and move the transducer until the display shows zero. Press the ZERO key to remove any small offset. Move the transducer by a measured amount (ideally to its full-scale position) and adjust the 'X' pot on the rear panel to trim the display to the correct value.

### 12.3.2 Unipolar Calibration

The two-channel version E725 is not normally set up for true unipolar calibration. A similar arrangement can be achieved via bipolar calibration and subsequent operation of the ZERO function from RUN mode for each display function. For example, for a  $\pm 2.5\text{mm}$  LVDT, calibrate to read  $\pm 2.500$ , move transducer to  $-2.500$  position, then press ZERO. This arrangement differs from a true unipolar calibration in that the RESET ZERO operation recovers a centre-zero (rather than end-zero) set up.



## 13 SPECIFICATION

The specification for the E725 AC input versions is as follows:-

Power supply	For supply identification, connections, tolerance and fuse values see Section 3.1 and 3.3.
Operating temperature.	Ac supply, -10 to +45°C, (14 to 113°F) Dc supply, -10 to +55°C, (14 to 131°F)
Dimensions	DIN437000. Width 92, height 44, depth 180 (inc. connectors)
Case material	Aluminium anodised black.
Weight	Ac supply. 0.51kg (excluding connectors) Dc supply. 0.43kg (excluding connectors)
Controls	Four membrane keys with tactile feedback Potentiometers for analogue output zero and gain.
Indicators.	5 digits, 13.2mm high. 4 LEDs for limits & 4 LEDs for function
Display resolution	1 in $\pm 99999$
Display update rate	3Hz
A to D resolution	1 in $\pm 99999$
Digital inputs	HOLD, ZERO, RESET, FAST ANALOGUE HOLD, opto isolated, 5 to 50V into 2k Ohms or TTL. (See also section 4.3).
Digital outputs	TTL for limits (see Section 9.2)
RS232/485	See section 12.
Connectors (Mating parts)	Transducer 9 pin D type male, Option 9 pin D type female (male if dual input) Digital I/O 15 pin D type male
Limits	See section 9.2
Transducer input & excitation	See section 5.1
Analogue output	See section 8.2

<b>EMC</b>			
The unit passed the following standards.			
a)	EN55022.	:	Conducted and radiated emissions
b)	EN61000-4 -2	:	Electrostatic discharge
	-3	:	Radiated immunity
	-4	:	Fast transient bursts
	-6	:	Conducted immunity
	-11	:	Supply voltage dip

Note: Because of the high gains involved when low output transducers are used, spurious display/analogue outputs may be seen in the presence of strong RF fields at certain frequencies. These frequencies will depend on:

- a) The cable length, especially the transducer's cable.
- b) Type of cable. (Quality of shield etc.)
- c) Cabling and grounding point Layout.

## 14 GLOSSARY OF TERMS

Analogue output	A continuously variable voltage or current signal proportional to a measured quantity.
Armature	The moving part of an LVDT or half bridge transducer.
Bipolar	Working in a range from a negative value, through zero, to a positive value.
Calculated channels	On 2-channel E725's where the channels are labelled A and B, the Calculated channels are A-B and (A+B)/2.
Calibration	Setting equipment (e.g. an E725 and a transducer) to give a known display or output for a particular measured quantity or range of quantities.
Calibration point	A point chosen for correlation between the physical quantity applied to a transducer and transducer output, E725 display or E725 output.
Calibration zero	The zero point defined during the main calibration procedure
Capacity	Alternative to full-scale.
Counts	Uncalibrated value displayed by E725.
D2-Series	A series of RDP manufactured LVDTs with integral signal conditioning providing dc-in/dc-out operation.
Displacement	General technical word for quantities such as distance, height, length, diameter etc.,
Electrical zero (point)	The armature position of an LVDT transducer at which the output is zero.
Engineering unit	A unit of measure of a physical quantity (e.g. In the case of displacement, mm).
Excitation (voltage)	The voltage applied to transducer to make it work.
Full-scale	The total specified measuring range of a transducer or instrument.
Function mode	In some cases the E725 can display A, B, A-B, (A+B)/2 or alternative Engineering units (mm, inches etc.). These display modes are called Function modes
Half bridge transducer	A transducer (usually strain gauge or inductive) requiring bridge completion components to operate with an E725
Hysteresis	(In the context of limits) A means of avoiding repeated re-triggering of a limit when the input signal dwells close to the set point.
Hysteresis	(In the context of transducers) An undesirable characteristic, the difference between the rising signal and the falling signal for the same physical quantity (similar to backlash in a machine).
IP65	A reference to a generally recognised Ingress Protection index. IP65 defines total protection against dust and low-pressure water jets from any direction.
Limit	A facility to indicate if a signal is above or below a particular level
Low pass	Term applied to electronic filters, which remove high frequencies and does not affect low frequencies.
LVDT	Linear Variable Differential Transformer, a type of transducer technology, particularly well suited to displacement measurement due to the non-contact nature of the sensing element.
Max	The maximum transducer reading stored since last reset.
Mechanical relay	Electronically operated switch with mechanical parts.
Min	The minimum transducer reading stored since last reset
Normal operating mode	The status of the E725 on power-up (after a short power-up sequence) where a calibrated E725 displays a measured quantity.
Opto-isolated	A means of protecting a digital input via an optical device, removing

	conventional electrical continuity.
Peak	Alternative for max
Polarity	Whether a quantity is positive or negative
Potentiometer	A variable resistor often used for making adjustments
RS232	A particular type of serial communication
RS485	A particular type of serial communication
Sensitivity	The relationship between transducer output, applied physical quantity and (in some cases excitation voltage)
Serial output	A means of transferring information or instruction in a digitally coded form.
Set point	The level at which a limit is triggered
Solid-state relays	An electronic device with similar features to a mechanical relay, but with no moving parts.
TIR	Total indicated reading, the difference between max and min
Transducer	An electronic measuring device which converts a physical quantity (e.g. pressure) into an electronic signal (e.g. voltage).
Trough	Alternative for min
TTL	Transistor Transistor Logic, the output of an IC.
Unipolar	Working in a range 0 to a positive value
V r.m.s.	Abbreviation of Volts (root mean square). A means of measuring an alternating voltage.
Valley	Alternative for min

15 APPENDIX 1 – DIMENSIONAL DETAILS

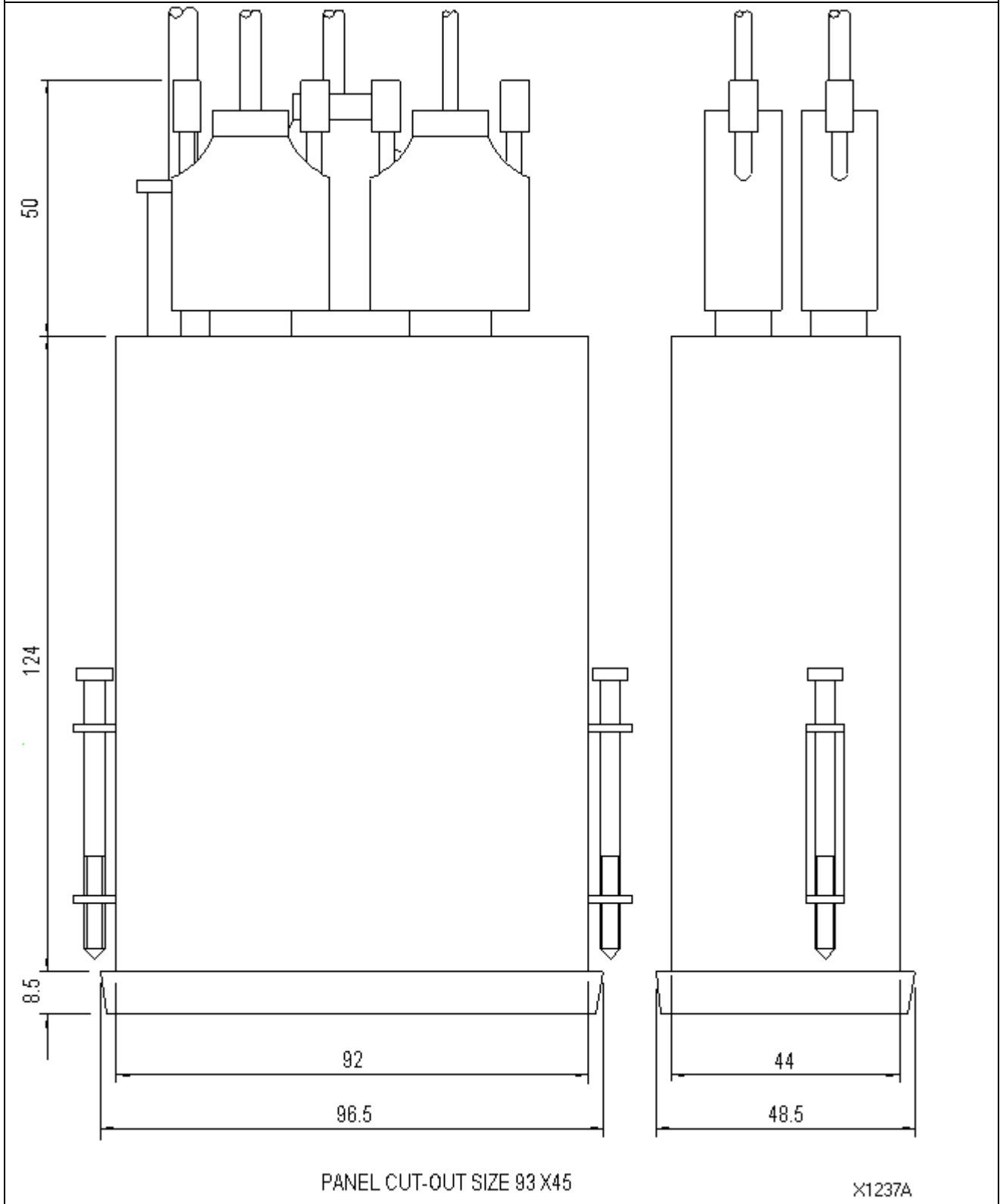

## 16 APPENDIX 2 – COMPLETE CONNECTION LISTING

E725 9-WAY CONNECTIONS (TRANSDUCERS AND OPTIONS)							
PIN	AC TRANSDUCER	DC TRANS (ALL VERSIONS)	OPT R	OPT RS	OPT FR	OPT FRS	OPT FM
1	Exc. High	Excitation +	RL1 N.O./N.C	RL1	RL1 N.O.	RL1	Max Out
2	Exc. Low (0V)	Excitation -	RL1 Com	RL1	RL1 Com	RL1	Min Out
3	Signal Low*	Signal +	RL2 N.O./N.C.	RL2	RL1 N.C.	No Con	TIR Out
4	Signal Hi*	Signal -	RL2 Com	RL2	RL2 N.O.	RL2	AN.Co m (0V)
5	0V (Ground)	0V (Ground)	RL3 N.O./N.C.	RL3	RL2 Com	RL2	Reset
6	M/S	Sh.Cal.1	RL3 Com	RL3	RL2 N.C.	No Con	5V Out
7	½ BR.R Hi	+15V Out	RL4 N.O./N.C.	RL4	L1 Logic	L1 Logic	Max CMP Out
8	½ BR.Com	-15/-8/-6V Out (DC1, 2, 3)	RL4 Com	RL4	L2 Logic	L2 Logic	Min CMP Out
779	½ BR.R Low	Sh.Cal.2	No Con	No Con	Logic Com	Logic Com	Dig.Co m (0V)

\* Reverse for 2AC Option

Transducer connectors are sockets, including 2AC, 2DC. Other options are plugs.

15-WAY CONNECTIONS (DIGITAL I/O)			
PIN	DIGITAL I/O	PIN	INPUTS
1	Rs232 rx	9	Reset/Mode
2	Rs232 tx	10	Reset/Zero
3	Rs232 Com.(Ground)	11	Reset/Limits
4	Limit 1 Out	12	Hold/Reset
5	Limit 2 Out	13	Fast Hold
6	Limit 3 Out	14	Com.
7	Limit 4 Out	15	(+5V Out)
8	Limit Com (Ground)		

On 9-15 way connect shields to shells

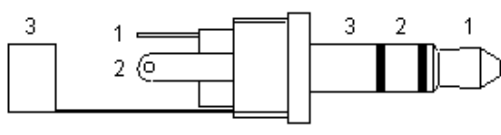
	ANALOGUE JACK	
	Contact	Function
	1	4-20mA
	2	±10V
3	0V (Com)	

SUPPLY AC/DC	
Brown	100-230V ac
Blue	Neutral
Green/Yellow	Ground
Red	V+ DC
Blue	V- DC
Shield	Ground

## 17 WARRANTY AND SERVICE

### WARRANTY.

R.D.P. Electronics products are warranted against defects in materials or workmanship. This warranty applies for one year from the date of delivery. We will repair or replace products that prove to be defective during the warranty period provided they are returned to R.D.P. Electronics.

This warranty is in lieu of all other warranties, expressed or implied, including the implied warranty of fitness for a particular purpose to the original purchaser or to any other person. R.D.P. Electronics shall not be liable for consequential damages of any kind.

If the instrument is to be returned to R.D.P. Electronics for repair under warranty, it is essential that the type and serial number be quoted, together with full details of any fault.

### SERVICE.

We maintain comprehensive after-sales facilities and the instrument can, if necessary be returned to our factory for servicing.

Equipment returned to us for servicing, other than under warranty, must be accompanied by an official order as all repairs and investigations are subject to at least the minimum charge prevailing at the date of return.

The type and serial number of the instrument should always be quoted, together with full details of any fault and services required.

### IMPORTANT NOTES.

1. No service work should be undertaken by the customer while the unit is under warranty except with the authorisation of RDP Electronics.
2. If the instrument is to be returned to R.D.P. Electronics for repair, (including repair under warranty) it is essential that it is suitably packed and that carriage is insured and prepaid. R.D.P. Electronics can accept no liability whatsoever for damage sustained during transit.
3. It is regretted that the above warranty only covers repairs carried out at our factory. Should the instrument have been incorporated into other equipment that requires our engineers to perform the repair on site, a charge will be made for the engineer's time to and from the site, plus any expenses incurred.

The aforementioned provisions do not extend the original warranty period of any product that has been either repaired or replaced by R.D.P. Electronics.

**THIS WARRANTY MAY BE NULL AND VOID SHOULD  
THE CUSTOMER FAIL TO MEET OUR TERMS OF PAYMENT.**