

TECHNICAL MANUAL TRANSDUCER AMPLIFIER TYPE S7CT

Doc. Ref CD1209J

The manual applies to units of mod status 3 ONWARDS



BS EN ISO 9001
Certificate No. FM13141



Affirmed by Declaration
of Conformity

USA & Canada
RDP Electrosense Inc.

2216 Pottstown Pike
Pottstown, PA 19465
U.S.A.

Tel (610) 469-0850
Fax (610) 469-0852
E-mail info@rdpe.com
www.rdpe.com

All other countries
RDP Electronics Ltd

Grove Street, Heath Town,
Wolverhampton, WV10 0PY
United Kingdom

Tel: +44 (0) 1902 457512
Fax: +44 (0) 1902 452000
E-mail: sales@rdpe.com
www.rdpe.com

INDEX

1.	INTRODUCTION.....	3
1.1	Important safety test information.	3
2.	CONNECTIONS.....	5
2.1.	Supply	5
2.2	MLP Transducer Connection Details	5
2.3	Sensagap & RCDT Transducer Connection Details	6
2.4	Dual Sensagap Transducers Connection Details	6
2.5	Amplifier Output Connection Details.....	6
2.6	Configuring Connections For Optimum EMC Compliance.....	6
3.	CONTROLS	9
3.1	Fine Gain Potentiometer VR2.....	9
3.2	Fine Zero Potentiometer VR1	9
3.3	Coarse Gain Switch SW1	9
3.4	Coarse Zero Jumper J3.....	9
3.5	Limit Level Potentiometers VR3, VR4.	9
3.6	Tempco. Jumper J2.....	9
3.7	Supply Voltage Selector Jumper J1.....	9
3.8	Voltage/Current Output Selector Solder Pad SP1	10
3.9	Relay Contacts Normally Open/Closed Solder Pads SP2, SP3	10
3.10	Jumper/Solder Pad Settings Summary:	10
4.	LIMITS OPERATION	11
5.	SETTING-UP PROCEDURES	12
5.1	MLP Transducer	12
5.2	Sensagap/RCDT Transducers (single channel)	12
5.3	Dual Sensagap Transducers (Thickness measurement).....	12
6.	SPECIFICATION.....	13
6.1	General.....	13
6.2	Amplifier	13
6.3	Limits	13
7.	APPLICATION NOTE : ELECTRICAL INTERFERENCE PROBLEMS.....	14
7.1	App. Note 2 Electrical Interference Problems	14
8.	WARRANTY AND SERVICE	16

Table of Figures

Fig. 1	Connector and Control Locations	7
Fig. 2	Under-board Control Locations	7
Fig. 3	Signal Cable Installation for Optimum EMC	8
Fig. 4	Limits Graphic	11

1. INTRODUCTION

The S7CT is designed for use with MLP, RCDT, Sensagap and MCL* transducers. The unit provides excitation and signal conditioning to produce 10v or 20mA output signals for a wide range of input levels. Two limit level detectors provide voltage-free contact outputs. The unit is housed in a robust, sealed aluminium case and may be powered from ac or dc supplies. In both cases there is isolation between supply and amplifier circuits.

*PD1499 is required for MCL. Refer also to CD1221.

Features include:

- (a) Designed for use with MLP and single or dual Sensagap
- (b) $\pm 10\text{v}$ or 4-20mA output selectable.
- (c) Two independent limit relay outputs.
- (d) 115/230v ac or 5/24v dc isolated supplies.
- (e) Wide gain range and zero range.
- (f) Case sealed to IP 65 specification.

1.1 Important safety test information.

ELECTRICAL SAFETY CHECKS

This instrument is designed to comply with BS4743 (IEC348) : "Specification for Safety Requirements for Electronic Measuring Apparatus". The specification complies with the EEC Directive 72/73/EEC concerning low voltage electrical safety.

The instrument was checked for electrical safety prior to despatch using a portable appliance test instrument.

If the user wishes to carry out his own tests, the following points must be followed:-

- (1) This Safety Class 1 apparatus has a low (<3A) fuse rating and a low current rated power connection cable.
- (2) It is recommended that when carrying out an earth bond test (BS4743, Section 9.5.5), the test current of 25A should not be applied for more than six seconds.
- (3). In general it is not recommended that high voltage (e.g. 1.5kV) insulation tests are carried out (BS4743, Section 9.7.4). This could cause damage to suppressor components.

INSTALLATION

The module may be orientated in any direction but preferably with the glands facing away from any splashing, etc. Resistance to humidity is consistent with the IP rating.

The supply voltage is normally set to 230v unless specified otherwise by the user. If this is changed from that indicated on the label then the label must be changed accordingly.

The unit should be protected from the effects of excessive shock and/or vibration.

DECLARATION OF CONFORMITY

**RDP ELECTRONICS LTD.
Grove Street Heath Town
Wolverhampton West Midlands
WV10 0PY
United Kingdom**

**We declare that the product described in this technical manual is manufactured by
RDP Electronics Limited and performs in conformity to the following:**

The Electromagnetic Compatibility Directive 89/336/EEC

The Low Voltage Safety Directive 72/23/EEC

**P. J. Smith, C.Eng., MIEE
Director
RDP Electronics Limited**

2. CONNECTIONS

2.1. Supply

THERE ARE TWO VERSIONS OF THE S7CT, ONE HAVING A DC POWER SUPPLY AND THE OTHER HAVING AN AC POWER SUPPLY. ADDITIONALLY, THERE ARE 3 DIFFERENT DC SUPPLY VERSIONS.

IT IS ESSENTIAL THAT YOU IDENTIFY WHICH YOU HAVE BEFORE PROCEEDING.

Refer also to Fig.1, label inside lid and transducer data sheet. All connections are made via glands, using cables of suitable diameter, and screw-terminal blocks.

AC Supply (Standard)

Terminal 1	Live (115/230V) (Customer selectable, see section 3.7)
Terminal 2	Ground/earth (internally connected to analogue common and case).
Terminal 3	Neutral

DC Supply (Option) (Specify with order)

Terminal 1	V+ (5/12/24V) (Depending on unit ordered)
Terminal 2	See notes below
Terminal 3	V-

Notes:

1. A floating power supply should be connected between V+ and V-.
2. If a ground referenced supply is used, terminal 2 will be half the supply voltage. Terminal 2 is internally connected to analogue output common and it is essential neither point is also connected to ground.
3. If a 3-wire power supply is used (e.g. $\pm 12V$ with a 24V supply S7CT), the positive supply would connect to terminal 1, centre tap to terminal 2 and negative supply to terminal 3.

2.2 MLP Transducer Connection Details

S7CT Terminal	Function	MLP Terminal
1	+15V excitation	4
2	0V excitation	2*
3	Signal Output	1
4	Signal Reference	3
5	No connection	*MLP terminal 2 is internally connected to the transducer case
6	No connection	

Important Note

A previous design of MLP had a different mechanical configuration and may have had different electrical connections. Please refer to Fig 1a and 1 b in CD1001 to establish the vintage of your MLP sensor and if you find it to be the old design, do not use the electrical connection information in this manual, instead contact RDP for connection information.

2.3 Sensagap & RCDT Transducer Connection Details

Terminal	Function	Sensagap / RCDT Wire
1	+15V excitation	Red
2	0V excitation	Blue and Screen
3	Signal Output	Yellow
4	Signal Reference	Black
5	No connection	The cable screen is internally connected to the transducer case.
6	No connection	

2.4 Dual Sensagap Transducers Connection Details

Used in applications to measure the thickness of a component situated in the gap between two facing transducers - see CD1003.		
Terminal	Function	Sensagap Wires
1	+15V excitation	Red 1, Red 2
2	0V excitation	Blue 1, Blue 2 and Screens
3	Signal 1 Output	Black 1
4	Signal 1 Reference	Yellow 1
5	Signal 2 Output	Black 2
6	Signal 2 Reference	Yellow 2

2.5 Amplifier Output Connection Details

Terminal	Function	
1	Relay 1 common	Limit Relay Outputs
2	Relay 1 N.O. (See Note 1 below)	
3	Relay 2 common	
4	Relay 2 N.O.	
5	Output $\pm 10V$ or 4-20mA (See note 2 below)	Analogue Output
6	Output common (0V)	
Note 1:	The contact sense can be changed from the "standard", normally open, to normally closed, by changing a solder link on the underside of the printed circuit board.	
Note 2:	The output is arranged to be voltage unless the current option is specified. The output type can be changed from voltage to current (or vice versa) by selection of solder link on the underside of the printed circuit board.	

2.6 Configuring Connections For Optimum EMC Compliance

For EMC compliance only screened multi-core cables should be used for the input and output connections to this instrument.

The screens of the two cables may be connected to the SCN terminal of the transducer connector, but for optimum EMC, connect the screens as shown in Fig.3.

ESD precautions should be used when working on the instrument with the lid removed. The user should ensure he is "earthed" by use of an earthed wrist strap or at least touching earth before touching any component including wires, terminals or switches.

Segregate signal/supply/output cables.

Fig. 1 Connector and Control Locations

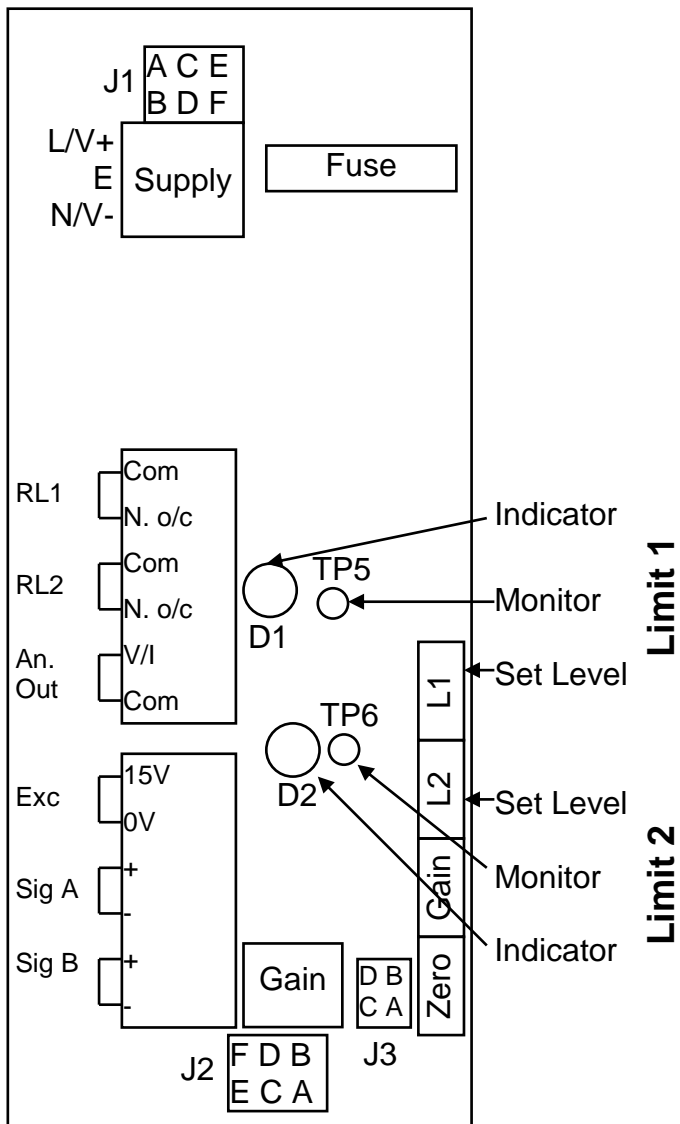

Fig. 2 Under-board Control Locations

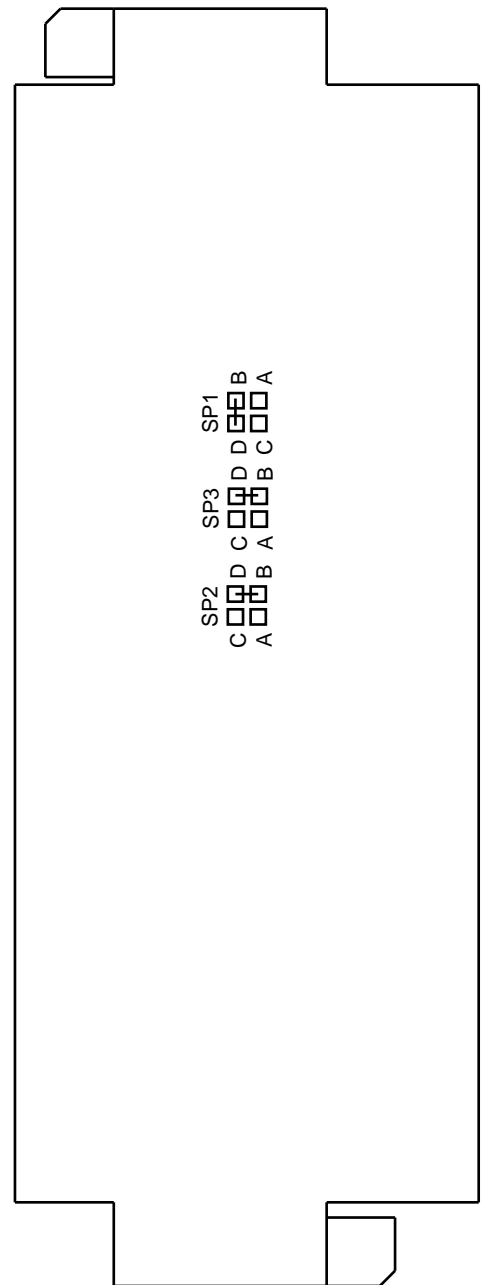
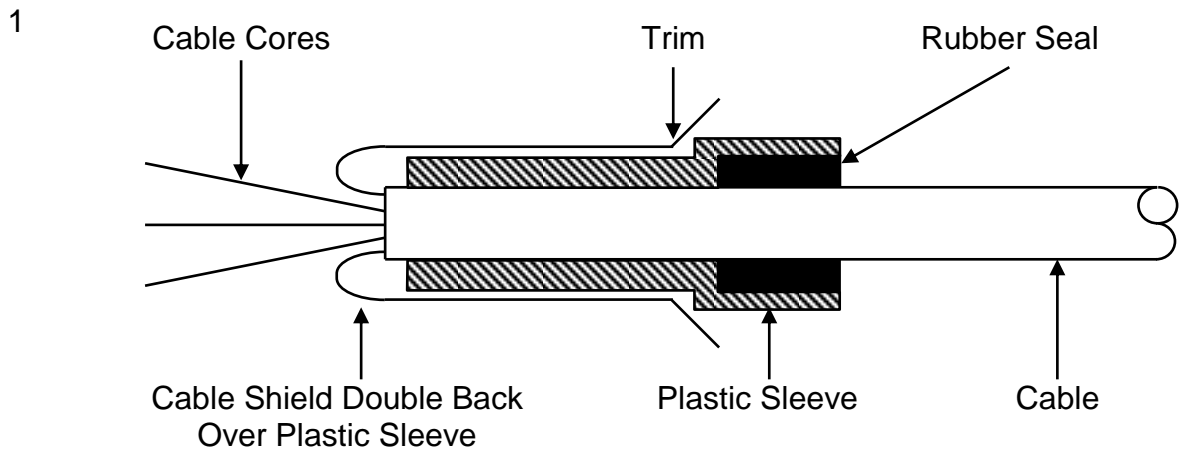
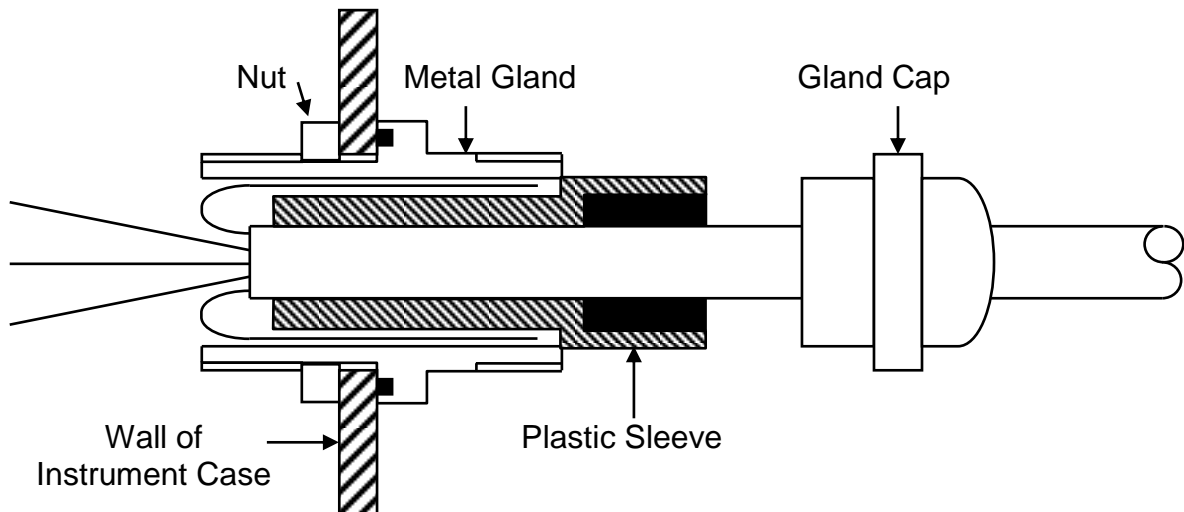

Fig. 3 Signal Cable Installation for Optimum EMC



2 Insert the end of the cable, plus the plastic sleeve into the metal outer shell of the gland. The bore of the gland is a tight fit onto the cable shield, giving the required ground contact.



3 Fit gland cap and tighten

3. CONTROLS

Refer also to Fig.1 and label inside lid.

These comprise multi-turn, screwdriver-adjusted potentiometers, solder pads, pin headers (jumpers) and DIL switch.

3.1 Fine Gain Potentiometer VR2

This provides a 3:1 adjustment of overall amplifier gain and, used together with the coarse gain switch, allows a wide range of input signals to produce 10v or 20mA output.

3.2 Fine Zero Potentiometer VR1

This provides a wide range of zero (or 4mA) adjustment and may be used together with the coarse zero jumper.

3.3 Coarse Gain Switch SW1

This is a two-lever DIL switch which, when used with the Fine Gain potentiometer, provides $\pm 10\text{v}$ or 20mA outputs for the input signals detailed in the table.	Lever ON	Input Signal (volts)
	None	0.3 to 1
	1	0.8 to 2.5
	2	2.4 to 7
	1 + 2	3 to 10

3.4 Coarse Zero Jumper J3

Units are normally supplied with J3 set to C-D. If extra zero adjustment is required, this can be changed. For a greater positive adjustment change to B-D; for a greater negative adjustment change to A-C.

3.5 Limit Level Potentiometers VR3, VR4.

Refer also to Section 4.

These controls set the output levels at which the relays operate. The two limits are independent and each is settable over the range $\pm 10\text{v}$ or 4-20mA	Limit 1 level is set by VR3
	Limit 2 level is set by VR4

3.6 Tempco. Jumper J2

The temperature coefficient of MLP transducer is improved via a special circuit in the S7CT when J2 is set to C-D.

For single Sensagaps this is not applicable and the jumper should be set to A-C.

When two Sensagaps are used, channel 2 must be enabled by setting the jumper to E-F.

3.7 Supply Voltage Selector Jumper J1

CAUTION: DISCONNECT SUPPLY BEFORE REMOVING PROTECTOR PLATE.

This is normally set to link A-C and D-F for 230V ac supplies.
For 115V ac supplies, change the links to A-B and C-D.

For dc supplies (5, 12, 24v), J1 is not used and may be left as for ac supplies above.

3.8 Voltage/Current Output Selector Solder Pad SP1
(Refer to Fig.2)

For voltage outputs (normal mode) this is linked B-D.

For 4-20mA current output this should be changed to A-C.

3.9 Relay Contacts Normally Open/Closed Solder Pads SP2, SP3
(Refer also to Fig.2)

These solder pads are normally linked B-D which connects the relay normally open contacts to the output terminals. To use the relays in normally closed mode, change the links to A-C.

3.10 Jumper/Solder Pad Settings Summary:

Application		J1	J2	J3	SP1	SP2	SP3
Transducers	MLP	-	C – D	See Note 2	-	-	
	Sensagap	-	A – C	C – D	-	-	-
	Dual Sensagap	-	E – F	B- D	-	-	-
Power Supply	230V	A-C + D-F	-	-	-	-	-
	115V	A-B + C-D	-	-	-	-	-
Analogue Output	Volt. O/P	-	-	-	B – D	-	-
	20mA O/P	-	-	-	A – C	-	-
Relay Output	Relay N.C.	-	-	-	-	A – C	A – C
	Relay N.O.	-	-	-	-	B – D	B – D

Notes:

1. Instruments are normally supplied for Sensagap/RCDT, 230V, Voltage output.
2. Instruments are normally supplied with J3 set C-D. If greater zero adjustment is required, change J3 to B-D or A-C. See Section 3.4.

4. LIMITS OPERATION

(Refer also to Fig.4 and Section 3.5)

Limit 1 is configured as a fail-safe "High" level detector, i.e. its relay is normally energised unless the signal level is higher (more positive) than the set level.

Limit 2 is configured as a fail-safe "Low" level detector, i.e. its relay is normally energised unless the signal level is lower (more negative) than the set level.

The levels may be set in either of two different ways:

- (a) Use a voltmeter to monitor the levels at TP5 (limit 1) and TP6 (limit 2) with respect to Output common (0v). The meter impedance should be >1MΩ. Adjust the limit level, set potentiometer RV3, 4 accordingly.
- (b) Adjust the transducer for the desired output signal level then adjust the limit potentiometer until the relevant LED changes state (red LED D1 for limit 1, green LED D2 for limit 2).

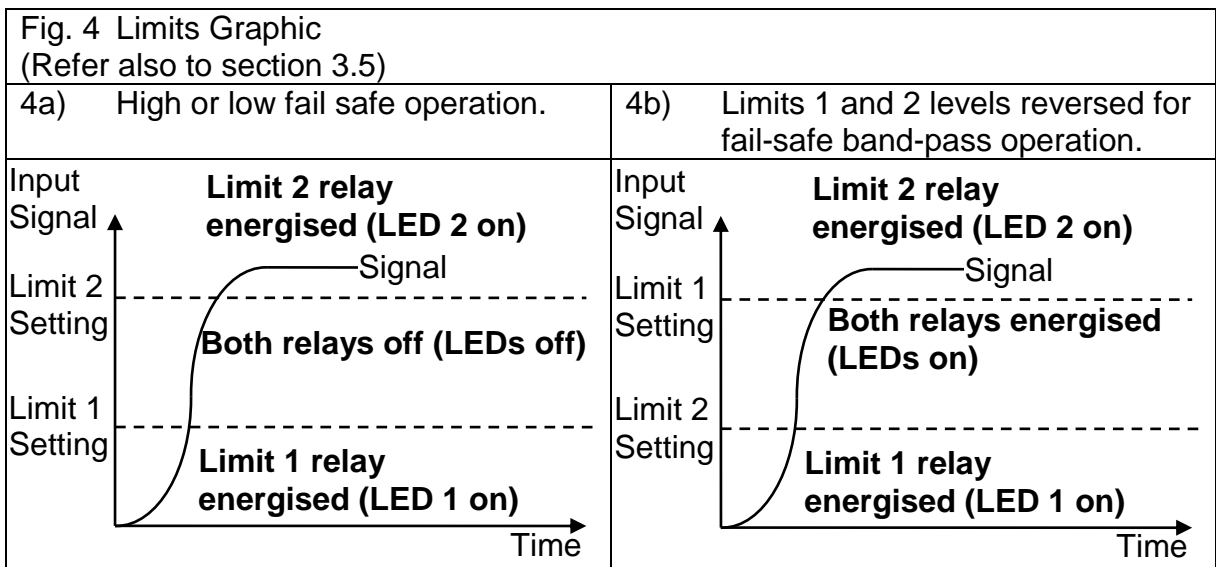

5. SETTING-UP PROCEDURES

For all types of transducer refer to section 2 for connection details and section 3 for control descriptions plus the specific transducer technical manual. For optimum accuracy allow 15 minutes warm-up for transducer and amplifier.

5.1 MLP Transducer

(Note: Ensure link J2 is fitted C-D).

- 5.1.1 Refer to the transducer calibration sheet for the signal output level and set the gain range switch to give the required output voltage (see section 3.3) e.g. for 10v output, lever 1 will normally be set to ON, 2 to OFF.
- 5.1.2 With zero pressure applied, adjust fine zero for 0v/4mA output (see section 3.2 & 3.4).
- 5.1.3 Apply a known pressure and adjust fine gain for the required output voltage or current.
- 5.1.4 Repeat steps 2 and 3 for consistent results.

5.2 Sensagap/RCDT Transducers (single channel)

(Note: Ensure link J2 is fitted A-C).

Note: for optimum performance, ensure the target is (a) connected to ground, (b) flat and (c) parallel to the transducer.

- 5.2.1 Refer to the transducer sensitivity figure on CD1003 and set the gain range switch to give the required output voltage (see Section 3.3), e.g. for 10v output, lever 2 will normally be set to ON, 1 to OFF.
- 5.2.2 Set the transducer target gap to (approximately) 0.5mm and adjust fine zero for 0v/4mA output (see sections 3.2 and 3.4).
- 5.2.3 Increase the gap by the required full-scale amount and adjust fine gain for the required output voltage/current.
- 5.2.4 Repeat steps 2 and 3 for consistent results.

5.3 Dual Sensagap Transducers (Thickness measurement)

(Note: Ensure link J2 is fitted E-F)

- 5.3.1 Refer to section 5.2 and 5.2.1 but note that the combined output of the two transducers may be up to 2 x that of a single transducer, hence select the gain range accordingly.
- 5.3.2 Position the Sensagaps with the target areas facing each other and separated by a gap of up to 2 x the nominal range for each transducer, e.g. if two 5mm sensors are used, the gap may be up to 10mm (with the 0.5mm zero offset this becomes effectively 11mm).
- 5.3.3 Insert a thin sheet of conductive material (e.g. steel, aluminium, etc.) between the sensors. The thickness of the sheet should be negligible compared to that of the

normal target. Adjust fine zero for 0v output. If the range of fine zero is inadequate, then fit link J3 B-D.

5.3.4 Replace the thin sheet with a target of full scale thickness and adjust fine gain for the required output voltage. Note: the target must always be $\geq 0.5\text{mm}$ from any transducer for linear results.

5.3.5 Repeat steps 3 and 4 for consistent results. Check that moving the target closer to either transducer (but not $< 0.5\text{mm}$) does not significantly affect the output signal.

6. SPECIFICATION

6.1 General

Supply Voltage ac	115 or 230V $\pm 20\%$ at 6VA. Fuse 250mA, HBC, A-S
Option:	
Isolated dc (single)	5/12/24V to order $\pm 10\%$ at 3VA. Fuse 1A
Operating Temperature	-10° to $+55^\circ\text{C}$
Dimensions	150mm L x 64mm W x 36mm H (6.0 x 2.5 x 1.42 inches)
Weight	550g/1.2lb
Gland Cable Size	3 to 6.5mm (0.12 to 0.25 inches)
Seals	IP65
Transducer Excitation	15V dc $\pm 5\%$ at 12mA max.
Regulation	0.005% typical
Temperature Coefficient	1.3mV/ $^\circ\text{C}$ typical

6.2 Amplifier

Gain Range	X1 to x35
Zero Range	$\pm 4\text{V}$ to $\pm 10\text{V}$ depending on gain
With J3 A-C	$+0/-8\text{V}$ to -10V depending on gain
Bandwidth	60 to 600Hz depending on gain
Noise	5mV pk-pk typical
Linearity	0.02% FS typical
CMRR	35dB typical
Input Impedance	200k Ω differential (both inputs)
Output	$\pm 10\text{V}$ at 5mA or 0/4-20mA into 0-400 Ω
Zero t.c.	0.004% FS/ $^\circ\text{C}$ typical
Gain t.c.	0.004% FS/ $^\circ\text{C}$ typical

6.3 Limits

Accuracy	$\pm 10\text{mV}$ typical
Hysteresis	20mV typical
Relay Contacts	1A at 24V dc/0.5A at 120V ac
Operate/Release	5mS/3mS

7. APPLICATION NOTE : ELECTRICAL INTERFERENCE PROBLEMS

7.1 App. Note 2 Electrical Interference Problems

When a Transducer Amplifier is used in an industrial application, some of the following points may be helpful to system engineers to design a trouble-free installation.

In general the operation of electronic instruments and transducers can be affected by electrical interference.

This interference can be generated by the switching of large or reactive loads on the supply causing the production of large voltage spikes and/or variation in the ac mains supply.

Higher frequency interference (radio frequency) is often generated by a large voltage (e.g. back emf from a coil) being switched by a contact. Generally a contact seen to arc whilst switching is producing RF interference. Other sources of RF include portable radios, telephones, etc.

The interference "signals" can enter a transducer measuring system in the following ways:

- a) Direct pick-up by wiring to the instrument. The wiring can be a connection to the transducer supply input or control (e.g. trip relay).
- b) Direct pick-up into the instrument.
- c) Along the mains supply lines.

There are two methods of countering these problems:

- a) Suppress the interference generation at source.
- b) Prevent the interference gaining access to the instrumentation circuitry.

Suppression at source is often the best approach. AC coils can often effectively be suppressed by means of connecting, as close to the coil terminals as possible, a 100 Ohm resistor in series with 0.1 μ F across the coil. Proprietary transient voltage clippers - either non-linear resistor or better semiconductor types - are very useful for suppression, mounted across coils and contacts.

Although RDP instruments are fitted with supply suppressors, an exceptionally noisy mains supply can be improved by means of a mains filter unit. These units in their simplest form consist of capacitors and inductors. Mounted at the point where the mains enters the instrument, they can be most effective. A constant voltage transformer is another effective way of cleaning up the mains.

Extra shielding of the transducer, cabling and instrument is a simple, low cost method of preventing particularly directed radiated RF type of interference.

Shielded cable should always be used to connect the transducer to the instrument. Shielded cable is often beneficial for other connections as well. The shield should only be earthed (grounded) at the instrument end.

It is not good practice to mount the instrument near to contactors, motors, switch transformers, solenoids, etc., but where it is considered necessary to mount the instrument near to such devices, an extra steel enclosure around the instrument would be essential.

In extreme cases, the transducer cable should be run in a steel conduit.

Trip relays fitted inside the Indicator should never be used to switch ac coils. The recommended arrangement is to use a dc slave relay as shown below.

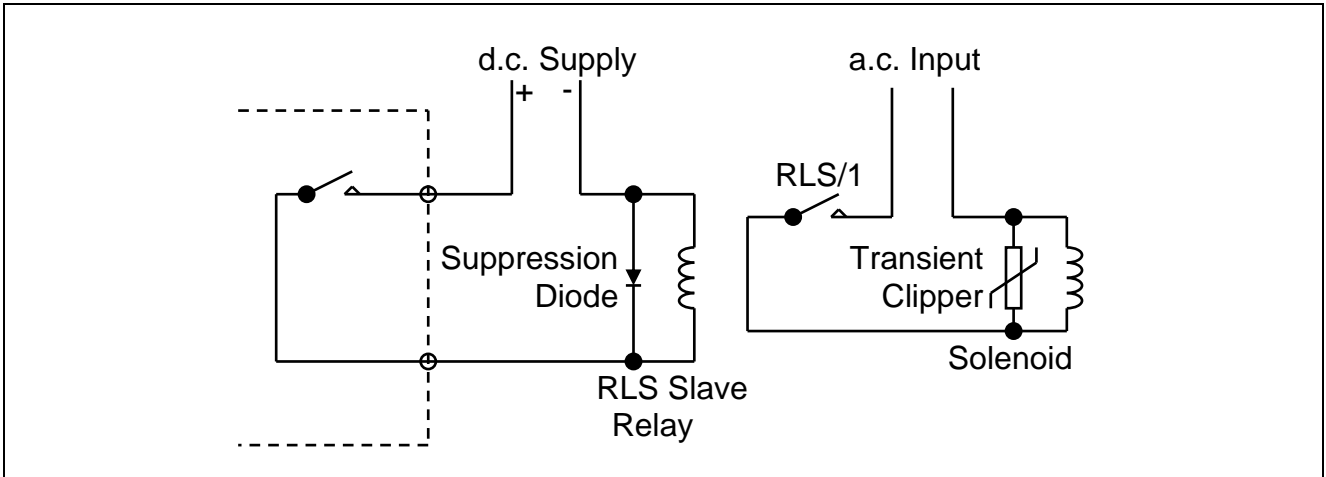

8. WARRANTY AND SERVICE

WARRANTY.

R.D.P. Electronics products are warranted against defects in materials or workmanship. This warranty applies for one year from the date of delivery. We will repair or replace products that prove to be defective during the warranty period provided they are returned to R.D.P. Electronics.

This warranty is in lieu of all other warranties, expressed or implied, including the implied warranty of fitness for a particular purpose to the original purchaser or to any other person. R.D.P. Electronics shall not be liable for consequential damages of any kind.

If the instrument is to be returned to R.D.P. Electronics for repair under warranty, it is essential that the type and serial number be quoted, together with full details of any fault.

SERVICE.

We maintain comprehensive after-sales facilities and the instrument can, if necessary be returned to our factory for servicing.

Equipment returned to us for servicing, other than under warranty, must be accompanied by an official order as all repairs and investigations are subject to at least the minimum charge prevailing at the date of return.

The type and serial number of the instrument should always be quoted, together with full details of any fault and services required.

IMPORTANT NOTES.

1. No service work should be undertaken by the customer while the unit is under warranty except with the authorisation of RDP Electronics.
2. If the instrument is to be returned to R.D.P. Electronics for repair, (including repair under warranty) it is essential that it is suitably packed and that carriage is insured and prepaid. R.D.P. Electronics can accept no liability whatsoever for damage sustained during transit.
3. It is regretted that the above warranty only covers repairs carried out at our factory. Should the instrument have been incorporated into other equipment that requires our engineers to perform the repair on site, a charge will be made for the engineer's time to and from the site, plus any expenses incurred.

The aforementioned provisions do not extend the original warranty period of any product that has been either repaired or replaced by R.D.P. Electronics.

**THIS WARRANTY MAY BE NULL AND VOID SHOULD
THE CUSTOMER FAIL TO MEET OUR TERMS OF PAYMENT.**

X WARRANTY AND SERVICE

WARRANTY.

R.D.P. Electronics products are warranted against defects in materials or workmanship. This warranty applies for one year from the date of delivery. We will repair or replace products that prove to be defective during the warranty period provided they are returned to R.D.P. Electronics.

This warranty is in lieu of all other warranties, expressed or implied, including the implied warranty of fitness for a particular purpose to the original purchaser or to any other person. R.D.P. Electronics shall not be liable for consequential damages of any kind.

If the instrument is to be returned to R.D.P. Electronics for repair under warranty, it is essential that the type and serial number be quoted, together with full details of any fault.

SERVICE.

We maintain comprehensive after-sales facilities and the instrument can, if necessary be returned to our factory for servicing.

Equipment returned to us for servicing, other than under warranty, must be accompanied by an official order as all repairs and investigations are subject to at least the minimum charge prevailing at the date of return.

The type and serial number of the instrument should always be quoted, together with full details of any fault and services required.

IMPORTANT NOTES.

1.No service work should be undertaken by the customer while the unit is under warranty except with the authorisation of RDP Electronics.

2.If the instrument is to be returned to R.D.P. Electronics for repair, (including repair under warranty) it is essential that it is suitably packed and that carriage is insured and prepaid. R.D.P. Electronics can accept no liability whatsoever for damage sustained during transit.

3.It is regretted that the above warranty only covers repairs carried out at our factory. Should the instrument have been incorporated into other equipment that requires our engineers to perform the repair on site, a charge will be made for the engineer's time to and from the site, plus any expenses incurred.

The aforementioned provisions do not extend the original warranty period of any product that has been either repaired or replaced by R.D.P. Electronics.

**THIS WARRANTY MAY BE NULL AND VOID SHOULD
THE CUSTOMER FAIL TO MEET OUR TERMS OF PAYMENT.**