

Technical Manual
TRANSDUCER AMPLIFIER
TYPE S7TW

Doc. Ref CD1210Z

This manual applies to units of mod status 13 ONWARDS



Affirmed by Declaration
of Conformity

USA & Canada
RDP Electrosense Inc.

2216 Pottstown Pike
Pottstown, PA 19465
U.S.A.

Tel (610) 469-0850
Fax (610) 469-0852
E-mail info@rdpe.com
www.rdpe.com

All other countries
RDP Electronics Ltd

Grove Street, Heath Town,
Wolverhampton, WV10 0PY
United Kingdom

Tel: +44 (0) 1902 457512
Fax: +44 (0) 1902 452000
E-mail: sales@rdpe.com
www.rdpe.com

INDEX

1. INTRODUCTION	3
2. INSTALLATION INSTRUCTIONS	5
2.1 EMC Requirements.....	5
2.2 Supply/Output Connections.....	5
2.3 Transducer Connections	6
2.4 TM202 on RDP transducers.....	7
3. CONTROLS.....	8
3.1 Coarse Zero Switch.....	8
3.2 Fine Zero Potentiometer	8
3.3 Zero Input Switch	8
3.4 Span Switch (Coarse gain)	8
3.5 Fine Span Potentiometer	9
3.6 Filter Switch.....	9
4. SETTING UP PROCEDURE.....	10
4.1 Bipolar or Half-stroke Applications	10
4.2 Offset Stroke Applications.....	10
5. SPECIFICATION	11
6. WARRANTY AND SERVICE	12
Index of Figures	
Fig. 1 General view of S7TW.....	5
Fig. 2 Connection for LVDT Transducers	6
Fig. 3 Connection Schematic.....	6
Fig. 4 Signal Cable Installation for Optimum EMC	7

1. INTRODUCTION

The S7TW is a two-wire, 4-20mA-output oscillator/demodulator for use with LVDT transducers having suitable primary impedance. (Refer to sect 5).

Coarse and Fine controls for gain and zero (4mA) allow use with the full range of RDP transducers and a filter switch allows selection of optimum bandwidth/noise. The differential signal amplifier circuit allows the use of long transducer cables.

The two-wire supply/output system allows use with long cables from the supply/monitor with a wide range of supply voltage and high noise immunity.

In order to meet the primary impedance requirements of the S7TW, some RDP transducers are modified to TM202. Section 2.4 refers.

Note: The S7TW is not suitable for use with differential or half-bridge transducers.

DECLARATION OF CONFORMITY

**RDP ELECTRONICS LTD.
Grove Street Heath Town
Wolverhampton West Midlands
WV10 0PY
United Kingdom**

We declare that the product described in this technical manual is manufactured by RDP Electronics Limited and performs in conformity to the following:

The Electromagnetic Compatibility Directive 2014/30/EU

The RoHS Directive 2011/65/EU

**R D Garbett
Director
RDP Electronics Limited**

2. INSTALLATION INSTRUCTIONS

2.1 EMC Requirements

For EMC compliance, good quality shielded cable should be used for connection to this instrument. **The shields of both transducer and 4-20mA loop cables should be connected as shown in Fig. 4.**

- Note 1 Cable shields to be grounded at only one end - the instrument end.
- Note 2 When the instrument is a small part of a large electrical installation, ensure the cables to and from the instrument are segregated from electrically noisy cables.
- Note 3 Ensure cables to and from the instrument are routed away from any obviously powerful sources of electrical noise, e.g. electric motors, relays, solenoids.
- Note 4 ESD precautions should be used when working on the instrument circuit board with the lid removed. The user should ensure he is "grounded" by use of a wrist strap or at least touching ground before touching any component including wires, terminals or switches.
- Note 5 The body of the transducer and the S7TW case should be grounded. If the transducer fixing attachments do not provide a good ground, then a ground strap should be used.

2.2 Supply/Output Connections

The two wires from the supply/output monitor are connected to terminals 6 and 7. Polarity of supply is irrelevant as a reverse polarity protection circuit automatically energises the oscillator/demodulator with the correct polarity.

Fig. 1 General view of S7TW

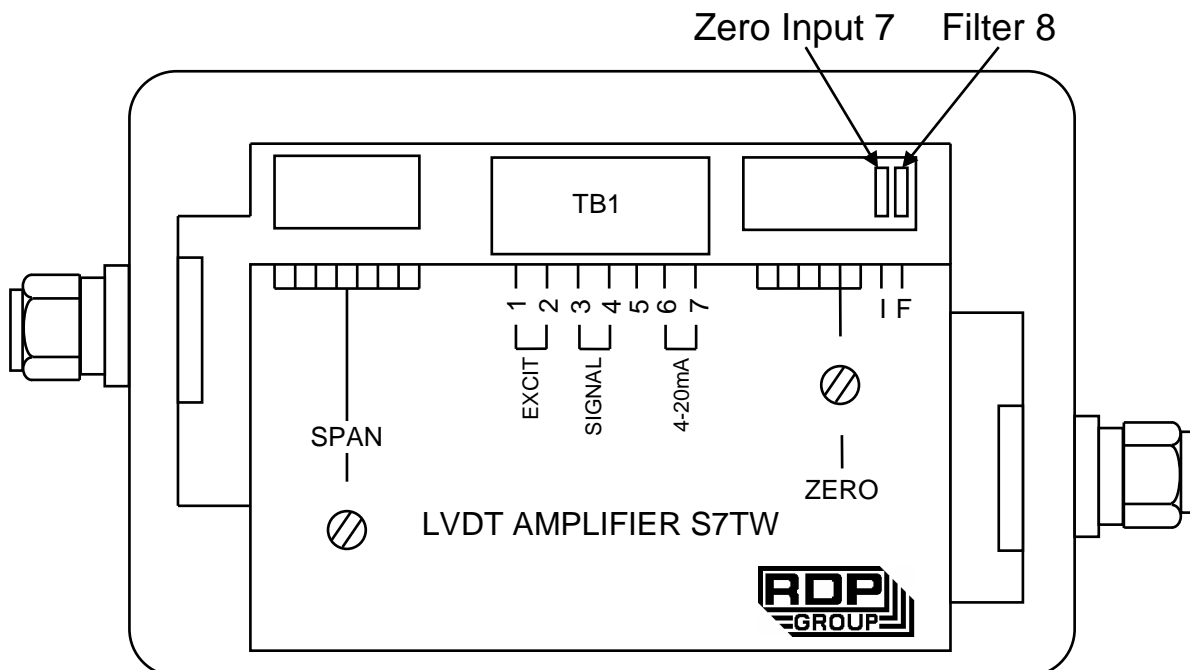

2.3 Transducer Connections

Fig. 2 Connection for LVDT Transducers

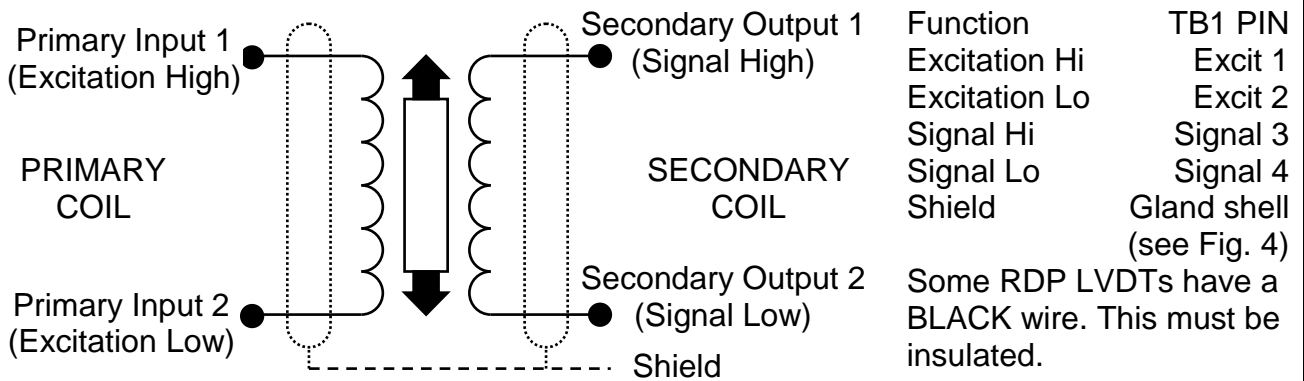

If when connected, the phase of the amplifier output is not as required (for example, an inward moving armature causes a rising amplifier output when a falling output is required) then reversing the signal high and signal low wires will correct this.

Fig. 3 Connection Schematic

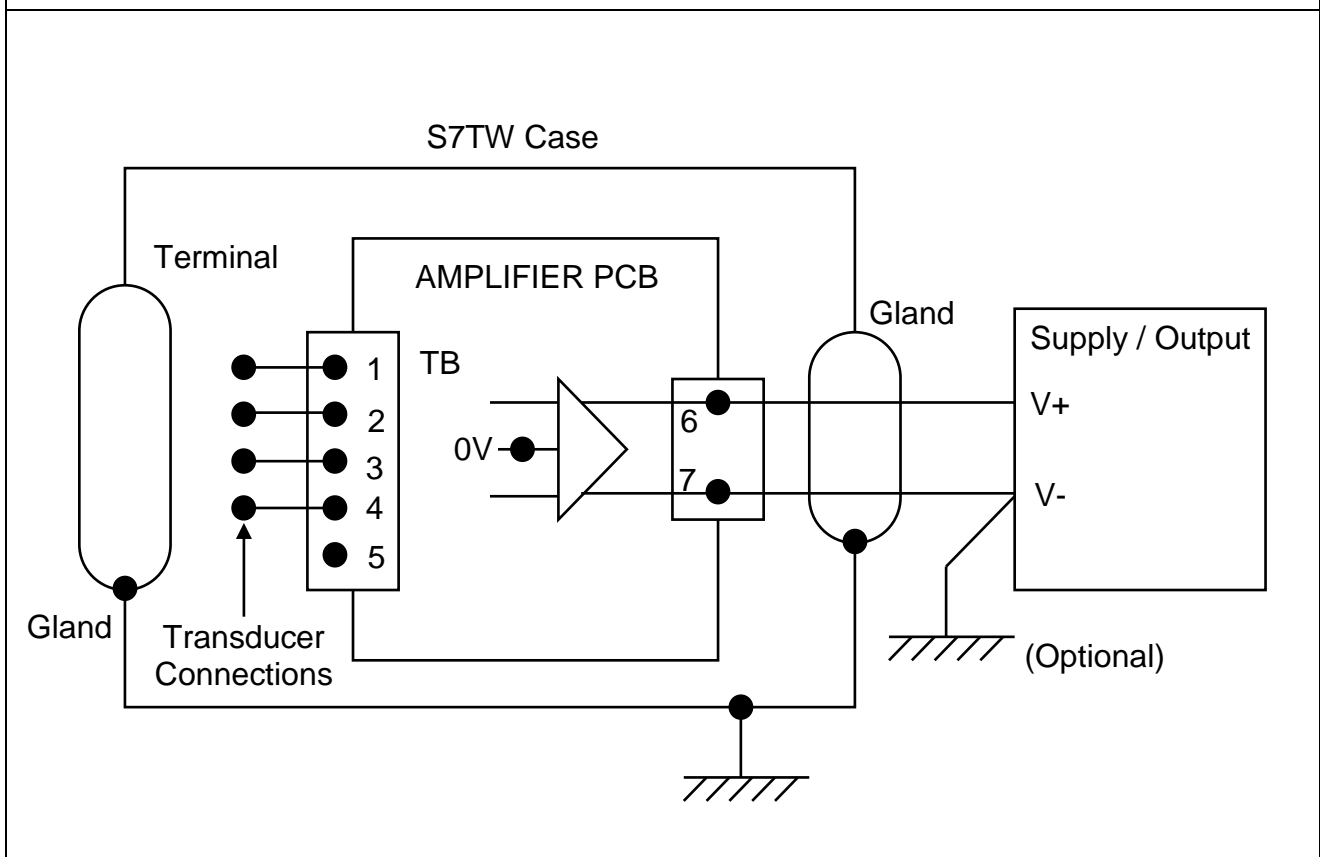
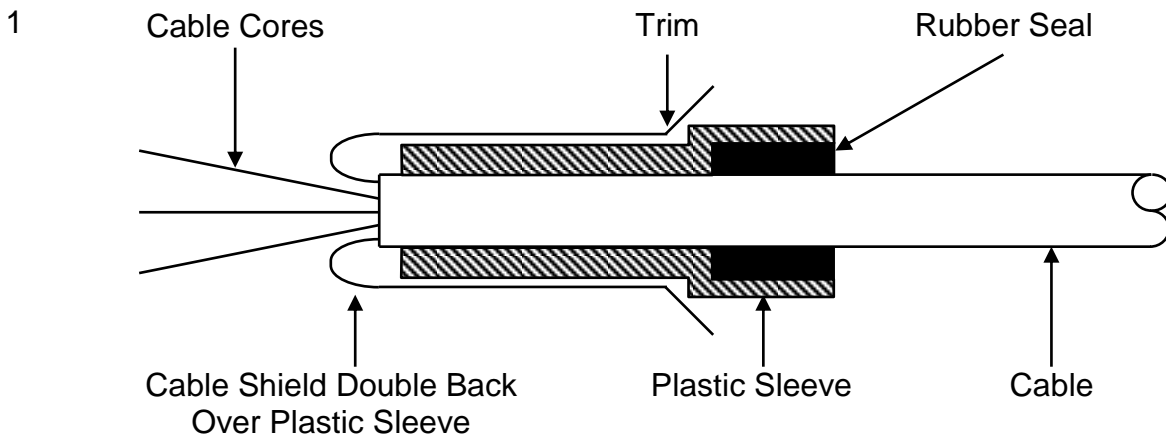
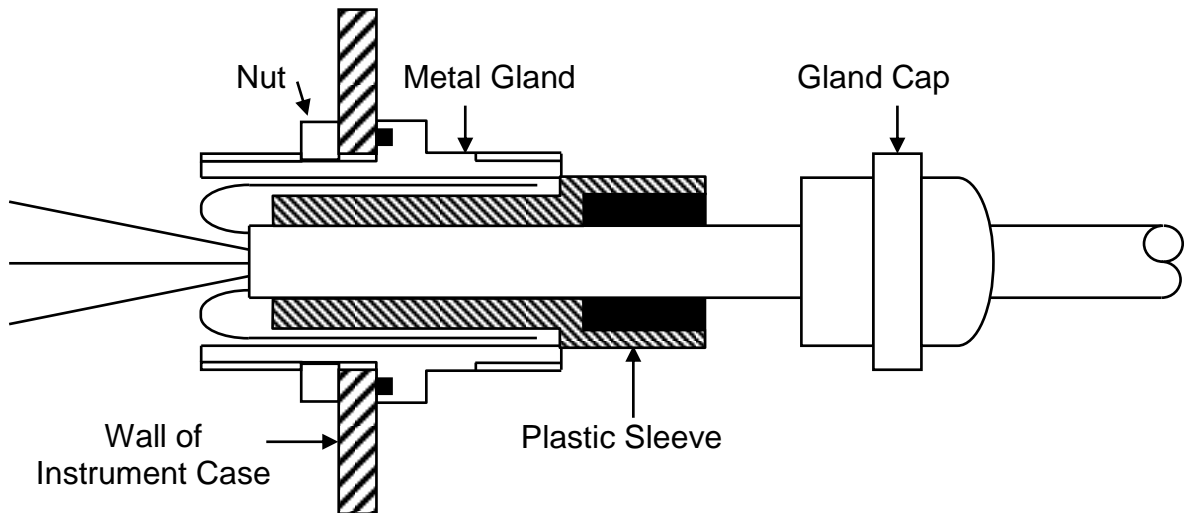

Fig. 4 Signal Cable Installation for Optimum EMC



- 2 Insert the end of the cable, plus the plastic sleeve into the metal outer shell of the gland. The bore of the gland is a tight fit onto the cable shield, giving the required ground contact.



- 3 Fit gland cap and tighten

2.4 TM202 on RDP transducers.

Some RDP transducers as standard have input impedance that is too low for use with the S7TW. To correct this, a modification is available (TM202) for these transducers. The modification code will be indicated on the transducer BUT if more than one modification is applied to the transducer, the code may not be TM202. In this case, contact the factory.

List of RDP transducers requiring TM202.

D5/25,	D5/25H,	D5/25K,	D525HK
D5/2000,	ACT2000,	ACW2000	(with any armature configuration)
D5/4000,	ACT4000,	ACW4000	(with any armature configuration)
D5/15000,	ACT15000,	ACW15000	with any armature configuration)
D5/18500,	ACT18500,	ACW18500	(with any armature configuration)

3. CONTROLS

Please refer also to Fig. 1 for locations. The locations of all controls are also shown on the legend plate mounted on the PCB.

3.1 Coarse Zero Switch

The toggles or levers 1 to 6 of an 8-way DIL switch are used to inject varying amounts of offset into the output signal circuit. This, together with the Fine Zero Potentiometer, allows aligning the 4mA output point to coincide with any desired armature position. For example, an ACT1000 can be made to give a 4-20mA output with a stroke of -0.5in. to +1in., etc.

The amount of offset for each lever setting is shown below:

Lever On	mA Output Shift (approx.)
1	-7
2	-5
3	-3
4	-2
5	+2
6	+3

3.2 Fine Zero Potentiometer

This control is used together with the coarse zero switch to set the 4mA output level. Refer also to Section 3.1. Avoid applying excessive tightening force to the locking nut.

3.3 Zero Input Switch

Toggle/lever 7 of the Zero Switch, when set to ON, zeroes the amplifier input signal irrespective of the transducer position. This simulates the transducer mid-stroke (zero output) signal and may be used to set the mid-range output level (e.g. 12mA) or transducer mid-stroke position without disconnecting the transducer secondary.

3.4 Span Switch (Coarse gain)

This is an 8-toggle/lever DIL switch which, when used with the Fine Span control, allows a 4-20mA output to be obtained with a wide range of transducer signals.

Typically, transducer manufacturers' data sheets or calibration certificates will give a figure allowing the full-scale output to be calculated. Possible formats for this are as follows; **the examples assume a transducer range of $\pm 50\text{mm}$.**

Sensitivity format	Explanation	To convert to F.S. output
mV/V/mm e.g. 46mV/V/mm	Millivolts of output, per volt of excitation, per mm of travel	Sensitivity x 0.5 x range in mm e.g. 0.046 x 0.5 x 50 = 1.15V
V/V at full-scale, e.g. 2.3 V/V	Volt of output, per volt of excitation, at full-scale	Sensitivity x 0.5 e.g. 2.3 x 0.5 = 1.15V
mV/mm at a specified excitation voltage. E.g. 230mV/mm at 5V exc.	Millivolts of output, per mm of travel, given a specified excitation voltage.	(Sensitivity / specified excitation voltage) x 0.5 x range in mm e.g. (0.230/5) x 0.5 x 50=1.15V
The standard excitation of the S7TW is 0.5V for mod 6 onward, as used in the calculations above.		

The following table shows the band of transducer full-scale output voltages appropriate to each of the 8 Gain Range Settings. For example, a transducer with a full-scale output of 1.15V would be correctly set as gain range 2.

The table below shows the V r.m.s. signals required for full output with the Fine Span either at minimum or maximum:	Lever On
2 to 4	1
1 – 2	2
0.7 – 1	3
0.4 – 0.7	None
0.25 – 0.44	4
0.15 – 0.25	5
0.1 – 0.15	6
0.05 – 1	7
0.03 – 0.05	8

3.5 Fine Span Potentiometer

This control interpolates between the ranges of the Span switch. (Section 3.4). Avoid applying excessive tightening force to the locking nut.

3.6 Filter Switch

Toggle/lever 8 of the "zero" DIL switch is used to select the bandwidth/noise performance as shown in the specification:

4. SETTING UP PROCEDURE.

4.1 Bipolar or Half-stroke Applications

1. Connect the transducer and supply as shown in Section 2.
2. Select the relevant gain range by setting the Coarse Span switch as shown in Section 3.4. Refer also to the transducer data to determine the input signal.
3. Set Zero Input lever to ON, all other Zero levers to OFF.
4. Adjust Fine Zero potentiometer for 12mA output.
5. Reset Zero Input lever to OFF and adjust the transducer armature for 12mA output. This determines the transducer centre stroke position.
6. Move the armature to the required full-scale position and adjust Fine Span for 20mA output. (Note: primary or secondary connections may be reversed to reverse the output polarity.)
7. Move the armature to the required zero position (an equal but opposite displacement to that in step 6) and check the output is 4mA. Trim Fine Span and zero if necessary for optimum linearity over the 4-20mA range.

4.2 Offset Stroke Applications

1. Carry out steps 1 to 5 in Section 4.1, then: -
2. Move the armature to the desired half-stroke position and use the Coarse Zero switch to suppress the output to near 12mA (refer to Section 3.1). Trim for exactly 12mA via Fine Zero.
3. Move the armature to the desired full-scale position and adjust Fine Span for 20mA output.
4. Repeat steps 2 and 3 for consistent results.
5. Move the armature to the desired 4mA position and check for 4mA output.

5. SPECIFICATION

(Note: all figures are typical values)

Supply Voltage	12 to 36V dc universal polarity						
Output regulation	1 μ A/V						
Loop Resistance (Max)	50 Ω (12V) to 1200 Ω (36V). See Note 1 below						
(Min)	See Note 2 below						
Output regulation	2 μ A/100 Ω						
Excitation	0.5V rms. 5kHz sinusoidal at 4mA max. (minimum impedance of transducer = 130 ohm)						
Amplifier: Input Signal Range	30mV to 4V						
Gain	2.5 to 333 (20mA equated to 10V)						
Input Impedance	100K ohm						
Zero Range	\pm 8mA						
Linearity	0.05%						
Bandwidth	250Hz flat						
Filter ON	25Hz						
Noise	50 μ A peak-peak						
Filter ON	15 μ A peak-peak						
Zero Temperature Coefficient	0.005% FS/ $^{\circ}$ C						
Gain Temperature Coefficient	0.015% FS/ $^{\circ}$ C						
Maximum Output Overload	45mA						
EMC Performance	When subjected to radiated electromagnetic energy (as EN61000-4-3) an additional error can occur at certain spot frequencies: <table border="1" style="margin-left: 20px;"> <thead> <tr> <th><u>Field Strength</u></th> <th><u>Typical Max. Error</u></th> </tr> </thead> <tbody> <tr> <td>30V/m</td> <td>0.5mA</td> </tr> <tr> <td>3V/m</td> <td>0.25mA</td> </tr> </tbody> </table>	<u>Field Strength</u>	<u>Typical Max. Error</u>	30V/m	0.5mA	3V/m	0.25mA
<u>Field Strength</u>	<u>Typical Max. Error</u>						
30V/m	0.5mA						
3V/m	0.25mA						
Operating Temperature	-20 to 85 $^{\circ}$ C (to 100 $^{\circ}$ C possible)						
Dimensions	125 x 80 x 57mm (4.7 x 3.2 x 2.1 inches)						
Weight	550g (1.2lb)						
Seal	To IP65						
Gland Cable Diameter	3 to 6.5mm (0.12 to 0.25 inches)						
Note 1	The maximum allowable total external circuit resistance is calculated from: $R_{max} = 50(V_s - 11)$						
Note 2	Where the supply voltage is higher than 28 volts and the ambient temperature higher than 25 $^{\circ}$ C, then a minimum value of loop resistance is required: $R_{min} = (V_s - 28)(t - 25)$ Where V_s = supply voltage (volts) and t = ambient temperature ($^{\circ}$ C) E.g. at 36 volts supply and 85 $^{\circ}$ C ambient, the value of RL must be between 480 ohms and 1200 ohms.						

6. WARRANTY AND SERVICE

WARRANTY.

R.D.P. Electronics products are warranted against defects in materials or workmanship. This warranty applies for one year from the date of delivery. We will repair or replace products that prove to be defective during the warranty period provided they are returned to R.D.P. Electronics.

This warranty is in lieu of all other warranties, expressed or implied, including the implied warranty of fitness for a particular purpose to the original purchaser or to any other person. R.D.P. Electronics shall not be liable for consequential damages of any kind.

If the instrument is to be returned to R.D.P. Electronics for repair under warranty, it is essential that the type and serial number be quoted, together with full details of any fault.

SERVICE.

We maintain comprehensive after-sales facilities and the instrument can, if necessary be returned to our factory for servicing.

Equipment returned to us for servicing, other than under warranty, must be accompanied by an official order as all repairs and investigations are subject to at least the minimum charge prevailing at the date of return.

The type and serial number of the instrument should always be quoted, together with full details of any fault and services required.

IMPORTANT NOTES.

1. No service work should be undertaken by the customer while the unit is under warranty except with the authorisation of RDP Electronics.
2. If the instrument is to be returned to R.D.P. Electronics for repair, (including repair under warranty) it is essential that it is suitably packed and that carriage is insured and prepaid. R.D.P. Electronics can accept no liability whatsoever for damage sustained during transit.
3. It is regretted that the above warranty only covers repairs carried out at our factory. Should the instrument have been incorporated into other equipment that requires our engineers to perform the repair on site, a charge will be made for the engineer's time to and from the site, plus any expenses incurred.

The aforementioned provisions do not extend the original warranty period of any product that has been either repaired or replaced by R.D.P. Electronics.

**THIS WARRANTY MAY BE NULL AND VOID SHOULD
THE CUSTOMER FAIL TO MEET OUR TERMS OF PAYMENT.**