



Technical Manual
LVDT'S
FITTED WITH E749L IN-LINE MODULES

Doc. Ref CD2557C



Affirmed by Declaration
of Conformity

USA & Canada
RDP Electrosense Inc.

2216 Pottstown Pike
Pottstown, PA 19465
U.S.A.

Tel (610) 469-0850
Fax (610) 469-0852
E-mail info@rdpe.com
www.rdpe.com

All other countries
RDP Electronics Ltd

Grove Street, Heath Town,
Wolverhampton, WV10 0PY
United Kingdom

Tel: +44 (0) 1902 457512
Fax: +44 (0) 1902 452000
E-mail: sales@rdpe.com
www.rdpe.com

LVDT'S FITTED WITH E749L IN-LINE MODULES

The E749L in-line module is a simple method of converting an AC LVDT into a DC in –DC out transducer. The E749L contains high quality electronics for energisation and signal conditioning. The E749L requires a +5 Volts regulated, or +6 to +18 Volts unregulated dc supply to give an output signal of ± 2.2 Volts that is electrically isolated from the input voltage.

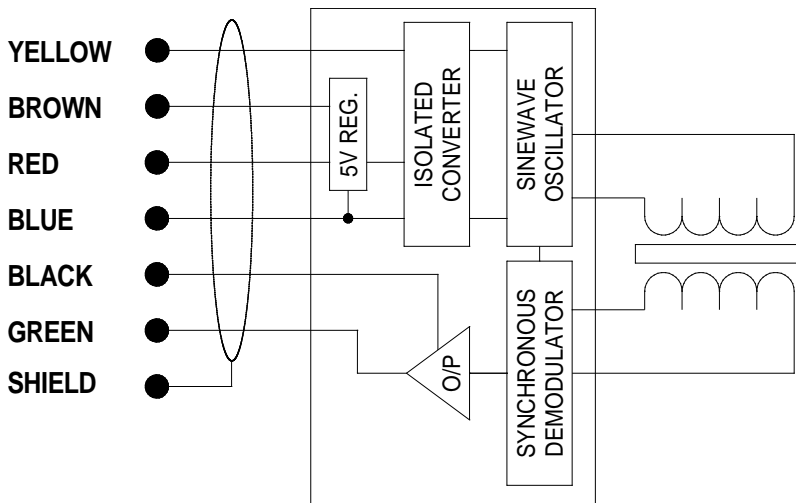

Connection Details

5V Supply	Cable Core Colour	6-18V Supply
+5V Input	Yellow	Connect to Brown
Insulate	Brown	Connect to Yellow
Insulate	Red	+6 to +18V dc
Supply Com (0v)	Blue	Supply Com (0V)
Output Low	Black	Output Low
Output High	Green	Output High
Instrument Ground	Shield	Instrument Ground

Note:

1. Incorrect connection may cause irreparable damage. Contact our Sales Department if you require assistance.
2. The transducer is factory-calibrated with an energising voltage of +15V, fitted with 2 metres of shielded cable.
3. To help prevent output noise and to comply with EMC requirements, it is preferable to connect cable shield to earth.

Operation with Long Cables

E749L modules are supplied with 2 metres of 6-core shielded cable unless longer length is requested when ordering. If a longer cable is ordered, or if the 2 metre cable is extended once purchased, there will be a voltage drop in the supply cable due to increased cable resistance in the increased length.

When using 5V supply:-

The largest voltage drop that is acceptable is 0.5v (10% of 5V). Therefore the largest supply cable resistance is:-

$$\frac{\text{Voltage drop}}{\text{Supply Current}} = \frac{0.5\text{V}}{0.06\text{A}} = 8\Omega, \text{ therefore } 4\Omega \text{ per core}$$

Example:

Wire Size	Longest cable length possible (including 2 metres factory-fitted)
16/0.2 0.5mm ² 20 AWG	80m
7/0.2 0.22mm ² 24 AWG	40m
7/0.1 0.055mm ² 30 AWG	11m

When using 6V to 18V supply:-

The link between the YELLOW and BROWN cores should be made at the end of the factory-fitted 2 metres of cable. This is to remove the voltage drop in these cores and only the drop in the RED and BLUE supply cores needs to be taken into account.

The longer the cable fitted the higher the supply voltage will need to be:

Minimum supply voltage required =

$$[(\text{Resistance of cable core}) \times (\text{Supply current}) \times (\text{Number of cores})] + 6\text{V}$$

$$= (\text{Resistance of cable core} \times 0.12) + 6\text{V}$$

Example:

WIRE SIZE	Minimum Supply voltage required with cable length at (including 2 metres factory-fitted)				
	5m	10m	20m	50m	100m
16/0.2 0.5mm ² 20 AWG	6.1V	6.1V	6.2V	6.5V	7V
7/0.2 0.22mm ² 24 AWG	6.1V	6.2V	6.3V	6.6V	7.3V
7/0.1 0.055mm ² 30AWG	6.5V	6.6V	7.2V	9V	12V

Output Noise (Ripple)

The output noise on E749L modules is 30mV peak to peak. This consists of 10kHz ripple with H.F. (>200kHz) superimposed on it.

This can be reduced to a 10mV peak to peak 10kHz ripple by the addition of an RC network across the output:

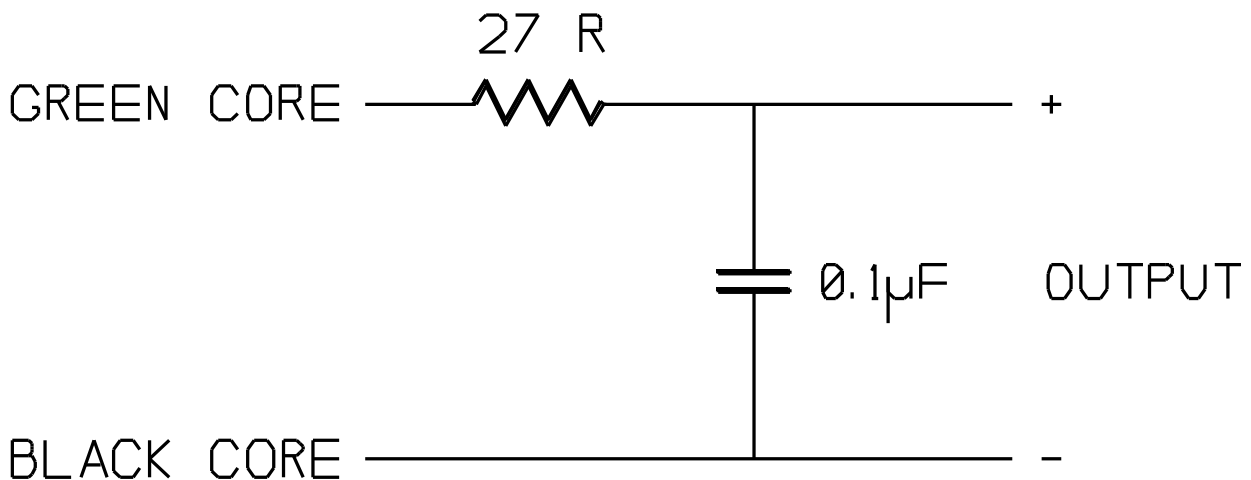

Specification

Input requirements	+5V dc $\pm 10\%$ regulated input, or alternatively +6V dc to +18V dc unregulated at 60mA typical
Linearity	$\pm 0.5\%$ of full range max. standard or $\pm 0.25\%$ and $\pm 0.1\%$ is available at extra cost in some models
Output Voltage	$\pm 2.2\text{V}$ dc nominal for working stroke (s/c proof) and isolated
Output Load (Minimum)	2k ohms
Output Ripple	30mV peak to peak
Output Bandwidth	200Hz (flat)
Output Impedance	2 ohms
Span Temp. Coefficient	$\pm 0.03\%$ FS/ $^{\circ}\text{C}$ (0.015%/FS/ $^{\circ}\text{F}$)
Operating Temp. Range	-20°C (-40°F) to $+70^{\circ}\text{C}$ (160°F)

Dimensions:

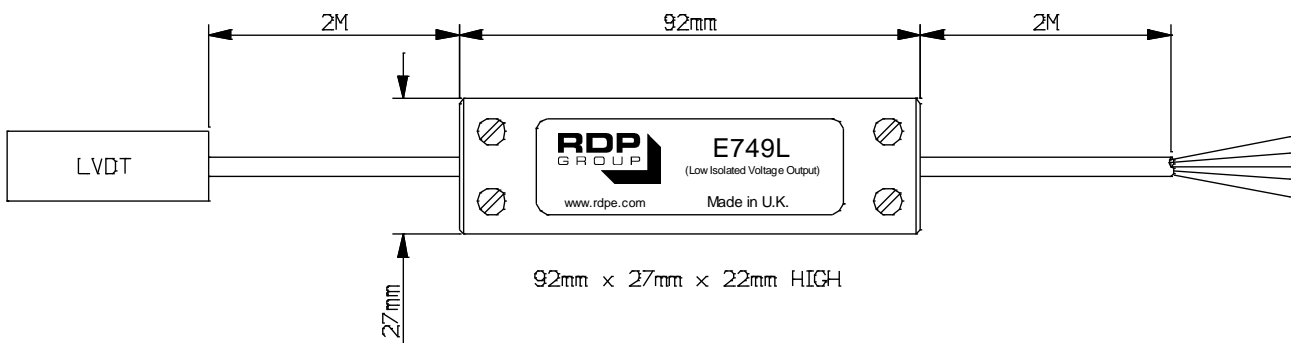

WARRANTY AND SERVICE

WARRANTY.

R.D.P. Electronics products are warranted against defects in materials or workmanship. This warranty applies for one year from the date of delivery. We will repair or replace products that prove to be defective during the warranty period provided they are returned to R.D.P. Electronics.

This warranty is in lieu of all other warranties, expressed or implied, including the implied warranty of fitness for a particular purpose to the original purchaser or to any other person. R.D.P. Electronics shall not be liable for consequential damages of any kind.

If the instrument is to be returned to R.D.P. Electronics for repair under warranty, it is essential that the type and serial number be quoted, together with full details of any fault.

SERVICE.

We maintain comprehensive after-sales facilities and the instrument can, if necessary be returned to our factory for servicing.

Equipment returned to us for servicing, other than under warranty, must be accompanied by an official order as all repairs and investigations are subject to at least the minimum charge prevailing at the date of return.

The type and serial number of the instrument should always be quoted, together with full details of any fault and services required.

IMPORTANT NOTES.

1. No service work should be undertaken by the customer while the unit is under warranty except with the authorisation of RDP Electronics.
2. If the instrument is to be returned to R.D.P. Electronics for repair, (including repair under warranty) it is essential that it is suitably packed and that carriage is insured and prepaid. R.D.P. Electronics can accept no liability whatsoever for damage sustained during transit.
3. It is regretted that the above warranty only covers repairs carried out at our factory. Should the instrument have been incorporated into other equipment that requires our engineers to perform the repair on site, a charge will be made for the engineer's time to and from the site, plus any expenses incurred.

The aforementioned provisions do not extend the original warranty period of any product that has been either repaired or replaced by R.D.P. Electronics.

**THIS WARRANTY MAY BE NULL AND VOID SHOULD
THE CUSTOMER FAIL TO MEET OUR TERMS OF PAYMENT.**